

9097247 TOSHIBA. ELECTRONIC

02E 17601 D

T-77-21

TA7780BN

MECHANISM DRIVER FOR IC LOGIC CONTROL

The TA7780BN is a mechanism driver IC designed for IC logic control, which is especially suitable for a cassette tape recorder or other tape-audio system application. It is necessary to use with a particular Programmable ROM Array IC (PRA IC), which is logic controller, TC9312N (TOSHIBA Corp.) or similar.

- Preparing the directly drive capability for the following mechanism.

RM (Reel Motor)

CM (Capstan Motor)

PL (Plunger)

- Including the ASO (Auto Shut Off) amplifier.
- Including the Thermal-Shut-Down circuit.
- Including the motor torque change circuit, which has normal speed and high speed. Therefore it is possible to do dubbing in high speed. Then that torque is changeable by means of external parts.
- Operation supply voltage range.: $V_{CC(opr)}=6\sim 12V$

Unit in mm

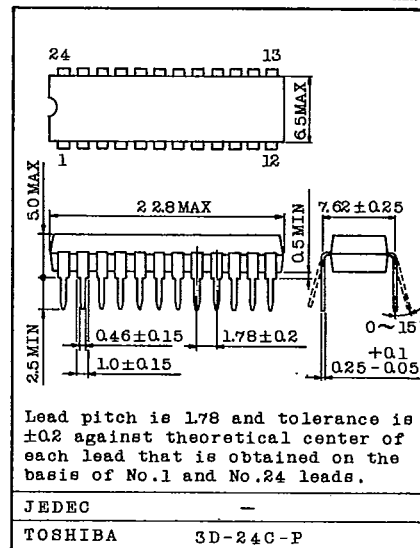

Weight : 1.2g

MAXIMUM RATINGS ($T_a=25^\circ C$)

CHARACTERISTIC	SYMBOL	RATING	UNIT
Supply Voltage	V_{CC}	15	V
Drive Current	Pin 9	$I_{CM} \text{ MAX}$	300
	Pin 8	$I_{PL} \text{ MAX}$	300
	Pin 7	$I_{PLC} \text{ MAX}$	60
	Pin 12, Pin 14 (Note 2)	$I_{RM} \text{ MAX}$	200
Power Dissipation (Note 1)	P_D	1200	mW
Operating Temperature	T_{opr}	$-25\sim 75$	$^\circ C$
Storage Temperature	T_{stg}	$-55\sim 150$	$^\circ C$

Note 1 : Derated above $T_a=25^\circ C$ in the proportion $9.6mW/^\circ C$.

Note 2 : Set up V_{CC} under 10V in case of I_{RM} above 100mA.

TOSHIBA

TA7780BN

ELECTRICAL CHARACTERISTICS (Unless otherwise specified, $T_a=25^\circ\text{C}$, $V_{CC}=12\text{V}$)

CHARACTERISTIC		SYMBOL	TEST CIR-CUIT	TEST CONDITION	MIN.	TYP.	MAX.	UNIT		
Quiescent Supply Current	ICCQ(1)	1	All outputs are opened. All inputs=0	$V_{CC}=12\text{V}$	3.1	3.8	5.7	mA		
	ICCQ(2)			$V_{CC}=6\text{V}$	2.5	3.2	4.5			
Operation Supply Voltage		V_{CC}	-		6	-	13	V		
LOGIC INPUTS	Input Voltage	"H" Level	V_{IH}	-	2, 3, 4, 5, 6, 11 pin Each Function operate.		3	-	6	V
		"L" Level	V_{IL}	-	Each Function does not operate.	2, 3, 4, 5, 11 pin	0	-	1.0	
	Input Current	"H" Level (1)	I_{IH1}	2		2, 3, 4, 5, 11 pin $V_{IH}=4\text{V}$		-	0.17	0.4
		"H" Level (2)	I_{IH2}	2	6 pin, $V_{IH}=4\text{V}$		-	0.35	0.75	
POWER OUTPUTS	RM Voltage	(1)	$V_{14(1)}$	3	$V_3=3.5\text{V}$, $I_{RM}=120\text{mA}$		10.5	10.9	-	V
			$V_{12(1)}$	3	$V_{CC}=12\text{V}$		-	0.26	0.75	
		(2)	$V_{14(2)}$	3	$V_3=3.5\text{V}$, $I_{RM}=120\text{mA}$		4.6	5.1	-	
			$V_{12(2)}$	3	$V_{CC}=6\text{V}$		-	0.29	0.9	
	RM Voltage (at PLAY, High Speed PLAY Mode)	V_{14} (High Speed PLAY)	$V_{14(\text{PLAY})}$	4	$V_{CC}=12\text{V}$ $I_{RM}=40\text{mA}$	$V_1=4.3\text{V}$ $V_6=3.5\text{V}$	4.2	5.1	6.0	V
			V_{14} (High Speed PLAY)	5	$V_3=3.5\text{V}$	$V_{23}=4.3\text{V}$ $V_2=3.5\text{V}$	4.2	5.1	6.0	
	PLQOUT Remaining Voltage	(1)	V_{OL8-1}	6	$V_{11}=4\text{V}$, $I_{PL}=300\text{mA}$ $V_{CC}=12\text{V}$		-	0.6	1.5	V
			V_{OL8-2}	6	$V_{11}=4\text{V}$, $I_{PL}=160\text{mA}$ $V_{CC}=6\text{V}$		-	0.35	0.6	
	PLCOUT Remaining Voltage		V_{OL7}	7	$V_6=4\text{V}$, $I_{PLC}=60\text{mA}$ $V_{CC}=12\text{V}$		-	0.9	1.3	V
	CMOUT Remaining Voltage		V_{OL9}	8	$V_6=4\text{V}$, $I_{CM}=300\text{mA}$ $V_{CC}=12\text{V}$		-	1.25	2.0	V
ASO OUT Remaining Voltage		V_{OL20}	9	$I=0.7\text{mA}$		0	-	1.0	V	
ASO Sensitivity		$V_S(\text{ASO})$	10	$C_{NF}=4.7\mu\text{F}$, $R_{NF}=56\Omega$		-	-56	-	dBV	
CM STARTER Remaining Voltage		V_{OL19}	11	$V_{15}=3\text{V}$, $I_{19}=5\text{mA}$		0	0.8	2	V	

AUDIO LINEAR IC

TA7780BN

BLOCK DIAGRAM

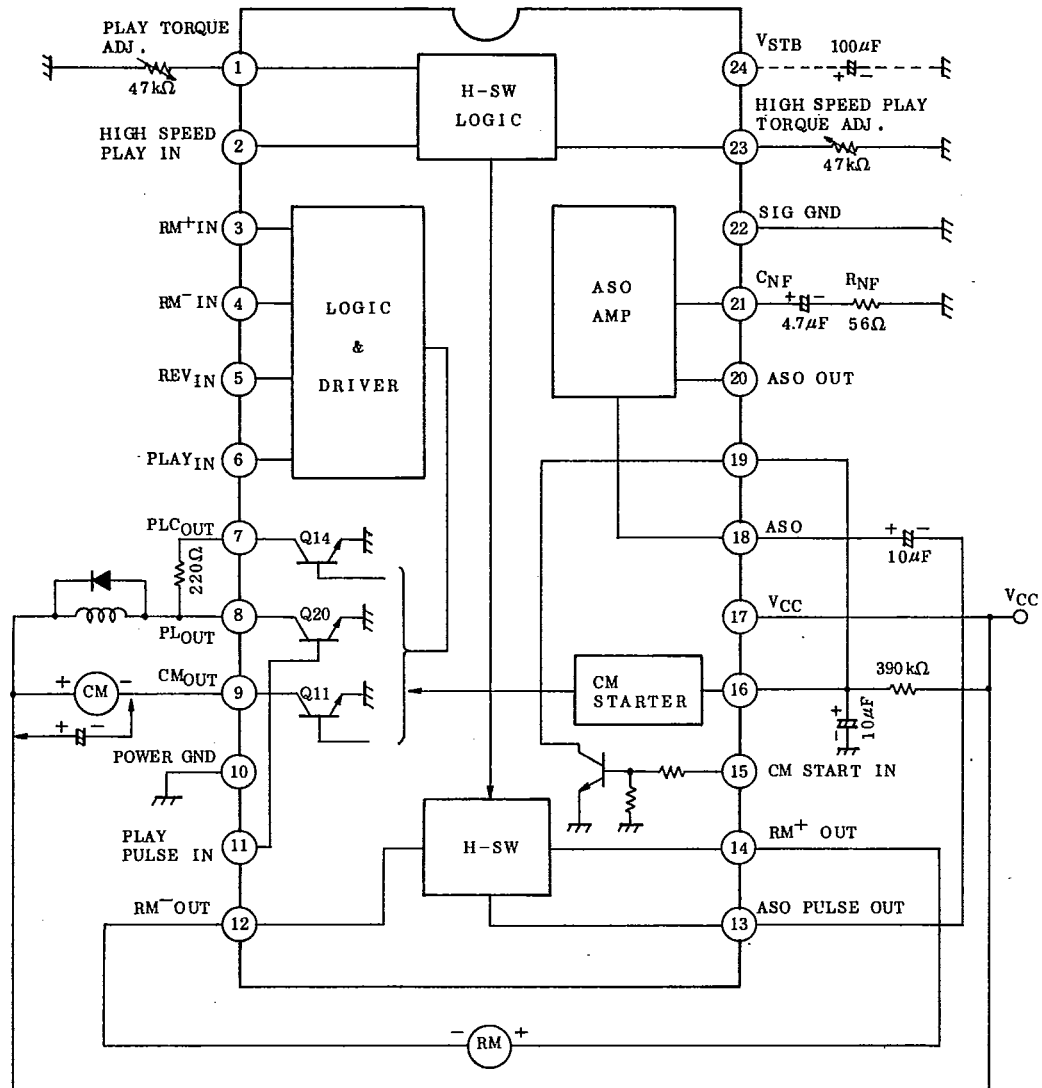

⊙ : Capstan Motor

⊙ : Reel Motor

PL : Plunger

TA7780BN

TEST CIRCUIT 1 : $I_{CC(1)}$, $I_{CC(2)}$

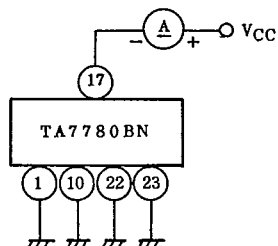

TEST CIRCUIT 2 : I_{IH}

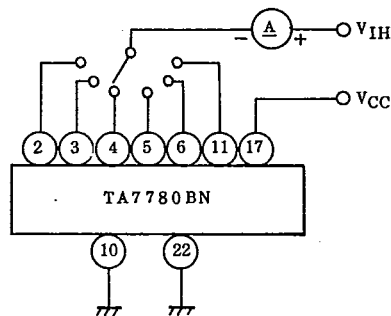

TEST CIRCUIT 3 : $V_{14(1)}$, $V_{12(1)}$
 $V_{14(2)}$, $V_{12(2)}$

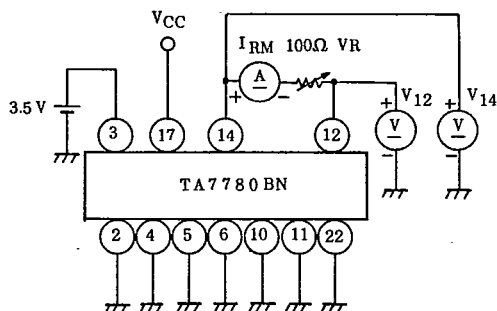

TEST CIRCUIT 4 : $V_{14(PLAY)}$

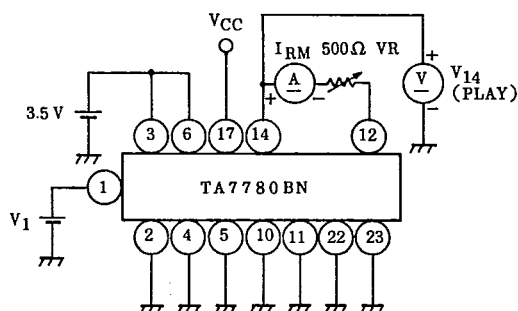

TEST CIRCUIT 5 : $V_{14(High\ Speed\ PLAY)}$

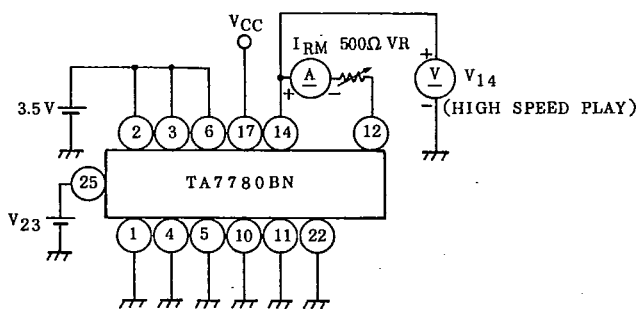

TEST CIRCUIT 6 : V_{OL8-1} , V_{OL8-2}

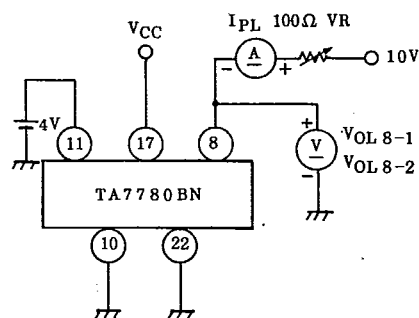

AUDIO LINEAR IC

TA7780BN

TEST CIRCUIT 7 : VOL7

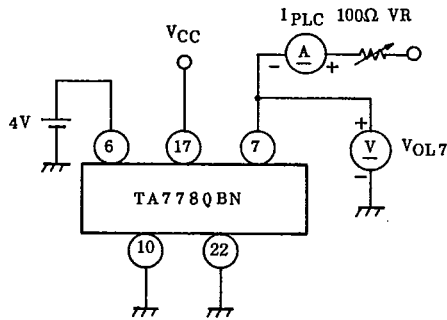

TEST CIRCUIT 8 : VOL9

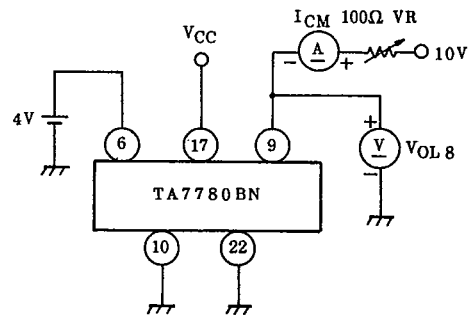

TEST CIRCUIT 9 : VOL20

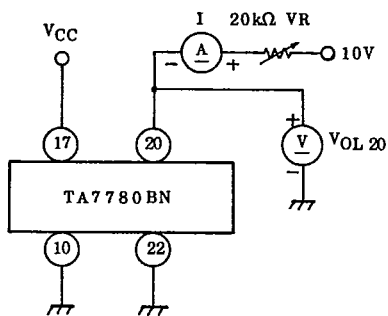

TEST CIRCUIT 10 : VS(ASO)

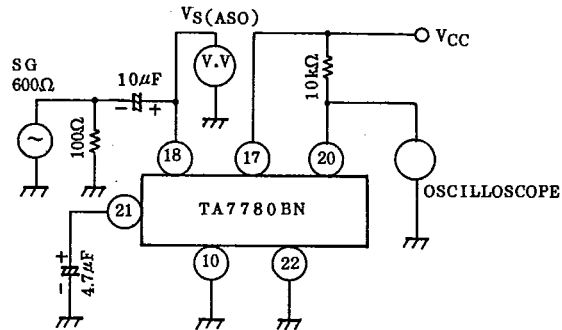

TEST CIRCUIT 11 : VOL19

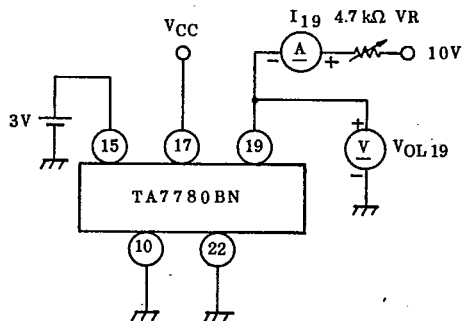

TA7780BN

APPLICATION SYSTEM CHART

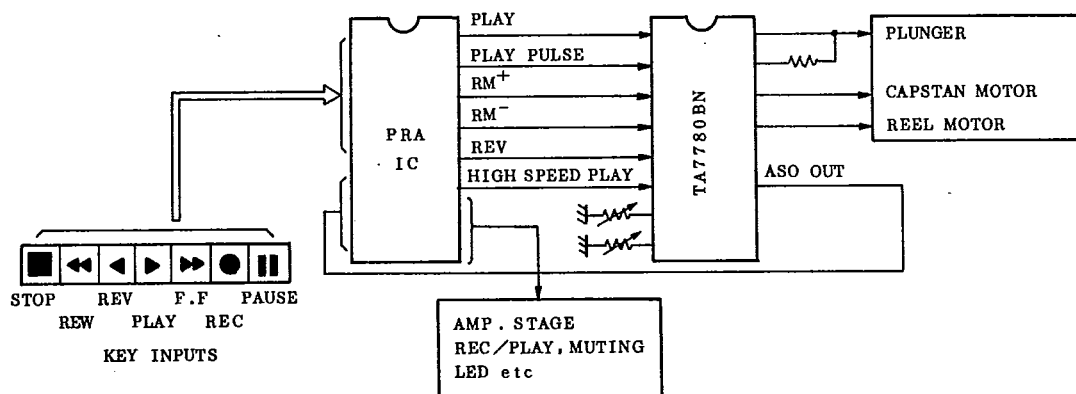

INFORMATION OF APPLICATION SYSTEM

The PRA IC is a particular Programmable ROM Array. That deals with the command signals from the key input section, and adjusts the timing of that six output at the same time. Then the PRA IC sends each of signals for the TA7780BN.

The TA7780BN, once more, deals with these signals more or less, and directly can drive RM, CM and PL of a tape recorder mechanism without external driver circuit.

In operating RM, this item keeps on generating the ASO signal. As RM stops, this signal stops. Therefore, as the ASO signal is fed to the PRA IC, this system detects a tape end.

For example, this signal is fed to the RESET terminal, which is the timer circuit within the PRA. So, this signal stopping at a tape end, the timer circuit starts operating. Then, with delay constantly, it is possible to set up the next operation, auto reverse, or auto stop, and so on.

TA7780BN

SYSTEM CHART

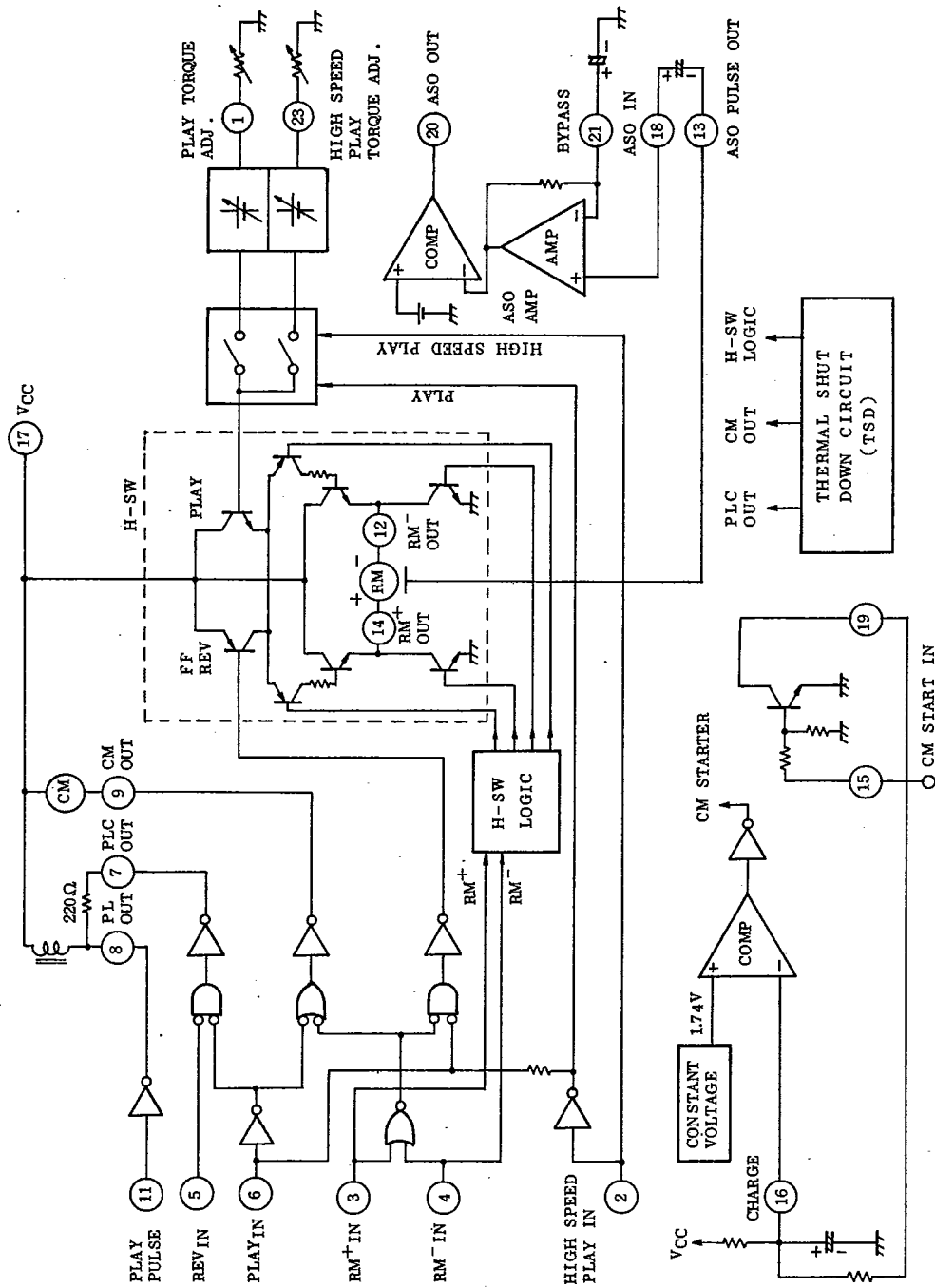

TA7780BN

APPLICATION INFORMATION

(1) Logic Circuit and Driver Circuit

The relations between each of inputs and each of outputs

1-1 PL OUT

The relation between this output and the input of PLAY PULSE is one-to-one, only, has logical negation.

1-2 PLC OUT

In case that the input of REV is "L" and the input of PLAY IN is "H", this output has "L".

Usually in PL starting, it is quickly-driven by large drive current momentarily, and afterward, the current reduces, is maintained. This large drive current flows from PL OUT, and the maintained current flows from PLC OUT. The PLC OUT current is adjustable, as the external resistance (220Ω) changes.

1-3 CM OUT

In case that any inputs of those, PLAY IN, RM⁺ IN and RM⁻ IN are applied, CM OUT has "L".

1-4 RM⁺ OUT and RM⁻ OUT

FUNCTION		INPUT CONDITION				OUTPUT	
		PLAY IN	RM ⁺ IN	RM ⁻ IN	HIGH SPEED PLAY IN	RM ⁺ OUT	RM ⁻ OUT
F.F		L	H	L	L	1.09V	0.26V
REW		L	L	H	L	0.26V	1.09V
PLAY (FORWARD)	PLAY	H	H	L	L	V ₍₁₎ + 0.8V	0.2V
	HIGH SPEED PLAY	H	H	L	H	V ₍₂₎ + 0.8V	0.2V
PLAY (REVERSE)	PLAY	H	L	H	L	0.2V	V ₍₁₎ + 0.8V
	HIGH SPEED PLAY	H	L	H	H	0.2V	V ₍₂₎ + 0.8V

* Each of voltages is measured for voltage applied to RM in following condition of ELECTRIC CHARACTERISTIC item;

at Normal Speed : in the condition of Voltage Applied to RM (1)

at High Speed : in the condition of Voltage Applied to RM (PLAY HIGH SPEED)

(Note) It is necessary not to make both of RM⁺ IN and RM⁻ IN "H". In case that those have "H" at the same time, large current flows into the H-SW circuit, then often destroys this IC.

AUDIO LINEAR IC

TA7780BN

1-5 REV IN

In case that the input of REV IN is "H", PLC OUT is forced to cut off momentarily. As this is turned off PL for a moment, it is useful for an auto reverse mechanism in the Forward/Reverse change.

(2) H-SW Circuit

Fig.1 shows the principle. At the FF or REW mode, Q34 is turned on, and Q45 is turned off. Q45 is turned on at PLAY mode, its base voltage is changed by the PLAY mode condition (Normal Speed PLAY or High Speed PLAY). The circuit under those transistors is, what is called, H-SW configuration. Q36, Q37, Q38, Q41 and RM is situated as "H" shape, therefore it is named thus. The direction of RM drive current is as following;

at Forward mode : Q36 → RM → Q37

at Reverse mode : Q41 → RM → Q38

This change is controlled by the H-SW LOGIC of inner circuit. And this H-SW circuit contains the ASO(Auto Shut Off) pulse generator circuit.

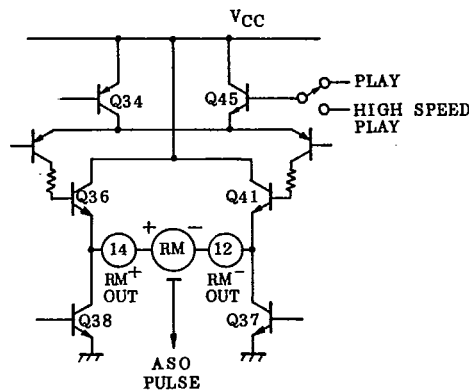

Fig. 1

(3) Torque Change Circuit

High speed PLAY is mainly used for the high speed dubbing of the double cassette tape recorder. Fig.2 shows the equivalent circuit.

[In case of the Forward mode.]

3-1 When the High Speed PLAY SW is turned on, the terminal pin 14 has a voltage which corresponds to that of the terminal pin 23. Therefore the applied voltage of the RM is given by,

$$|V_{14}-V_{12}| \approx V_{23} + V_{BE} - 2V_{CE(sat)} = V_{23} + 0.6V \quad (@ I_{RM}=40mA)$$

When the Normal Speed PLAY SW is turned on, the applied voltage is given by,

$$|V_{14}-V_{12}| \approx V_1 + V_{BE} - 2V_{CE(sat)} = V_1 + 0.6V \quad (@ I_{RM}=40mA)$$

In proportion as temperature rises this applied voltage rises because of the VBE temperature characteristic. This characteristic compensates the temperature characteristic of the RM torque.

TA7780BN

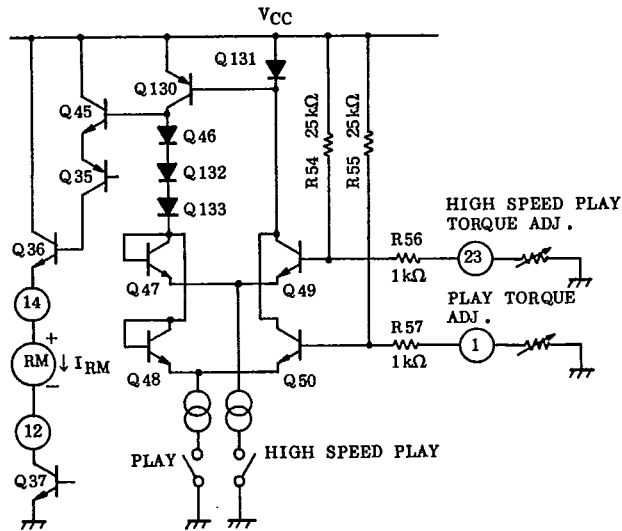

Fig. 2

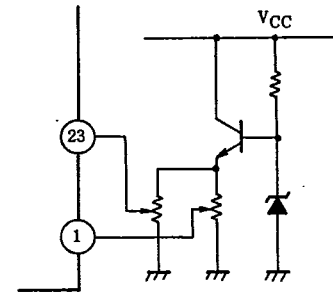

Fig. 3

3-2 The establishment of 23 (or 1) pin's voltage.

In case of the potentiometer is used, it is necessary to stabilize the applied voltage by the zener diode as shown in Fig.3. Because, it is delicate for the regulation of the supply voltage. And, it is possible to apply the regulated voltage directly.

3-3 In case of the High Speed PLAY mode is not used.

It is necessary to connect the terminal pin 23 to GND line or the terminal pin 1. (Don't open this terminal.) Because, the Base of the transistor Q49 is connected to the VCC line through the resistance R54, so the reverse current flows from the Emitter of the transistor Q47 to the Base of that, and then the voltage of it's Collector is not to be followed by the voltage of the terminal pin 1. And, when the High Speed PLAY mode is used, it is necessary to set up the potential difference between the terminal pin 1 and pin 23 under 5V as same reason.

TA7780BN

3-4 RM Current (I_{RM}) and Torque Voltage (V_1 , V_{23})

It is necessary to satisfy next equation.

$$V_1 \text{ (or } V_{23}) \geq (0.454/K) \cdot I_{RM} + 0.76V + (0.017 \times V_{CC})$$

K is changed by the value of I_{RM} .

$$\left[\begin{array}{l} K=60 \text{ @ } I_{RM}=40\text{mA} \\ K=45 \text{ @ } I_{RM}=100\text{mA} \\ K=20 \text{ @ } I_{RM}=150\text{mA} \end{array} \right]$$

When the Torque Voltage is under this value, pulse noise from the Capstan Motor and power source ripple appears on the terminal pin 13, and this causes ASO circuit malfunction.

And besides, don't set up this voltage under 1V.

(4) ASO Amplifier and Comparator

The pulse signal which is generated by the RM turning appears on the terminal pin 13, and it is transmitted to the terminal pin 18 by the external condenser C_{IN} . Then this pulse signal is amplified by the ASO Amplifier and is done the waveform shaping by the Comparator. The terminal pin 20 is the terminal of this pulse signal's output. Therefore, it is possible to notice what the RM stops or not by the presence of this pulse signal. (Tape end detection.)

Fig. 4 shows the equivalent circuit.

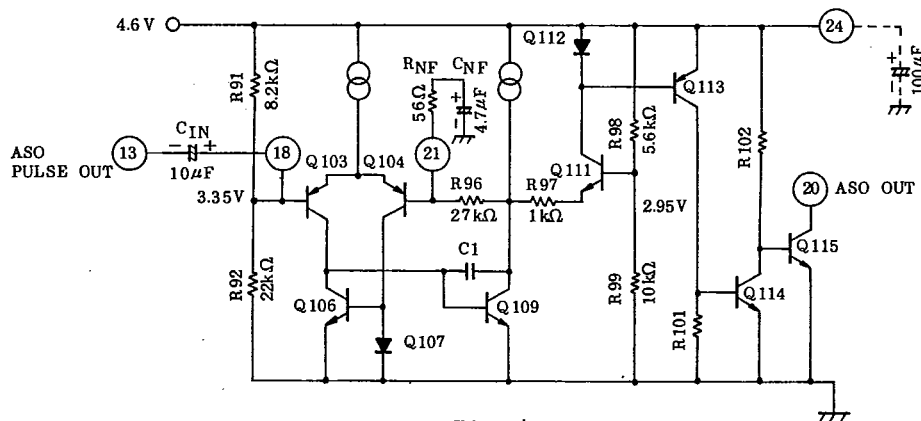

Fig. 4

4-1 It is possible to adjust the voltage gain of this amplifier by the external resistance R_{NF} .

At $R_{NF}=56\Omega$, ASO sensitivity is about -56dBV ($1.58\text{mV}_{\text{rms}}$). When R_{NF} is over 500Ω , this amplifier oscillates, so use it under 500Ω .

TA7780BN

- 4-2 Low frequency characteristic of this amplifier is determined by (C_{IN} , R_{91} , R_{92}) and (C_{NF} , R_{NF} , R_{96}). If C_{IN} is too small, it will easily pick up ripple of the constant-voltage regulated power supply (4.6V). In this case, connect the by-pass condenser between the terminal pin 24 and GND line. High frequency characteristic is determined by the internal condenser C_1 , and the Roll-off frequency is about 45kHz.
- 4-3 The transistor Q109 is switched by the input pulse signal. And the base voltage of the transistor Q111 is about 2.95V, therefore, if the collector voltage of the transistor Q109 is under 2.25V, the transistor Q111 turns on and then the transistor Q115 turns off. So, ASO out (pin 20) is "H". On the other hand, when the collector voltage of the transistor Q109 is over 2.25V, ASO out is "L". This ASO output signal is used as the reset signal for the counter of the PRA IC. Therefore, if the RM is stopped compulsorily at the tape end, the mechanism becomes the stop condition because of this reset signal disappearance.

(5) CM Starter and CM START IN

5-1 CM Starter

In throwing in supply voltage, this circuit operates CM for a period, then it is possible to wind up a loose tape. This period is determined by the CR-time constant.

$$t = -CR \cdot \ln\left(1 - \frac{1.74V}{V_{CC}}\right)$$

And in cutting off supply voltage, this circuit operates for a period.

- 5-2 In case that the level of the terminal pin 16 is "L", it is capable to operate CM independently.

This function is in spite of the control pulse, PLAY IN, RM^+ IN and RM^- IN.

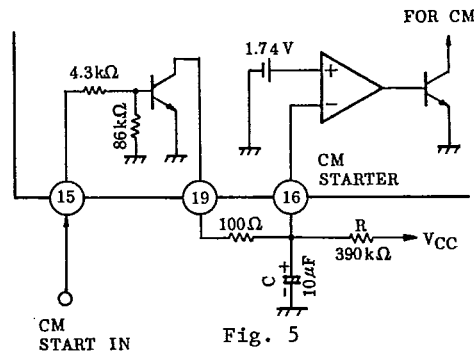

Fig. 5

TA7780BN

5-3 CM START IN

As connected as Fig.5, in case that the level of the terminal pin 15 is "H", it is possible to operate CM. In operating directly CM with CM out (9 pin), extra pulse, which is generated by CM, occasionally causes the malfunction of the ASO circuit. In this case, as connected to external transistor as Fig.6, it is capable to divide two GND. So, it is possible to improve that. In this connection, it is also possible to control the CM by the terminal pin 15 independently.

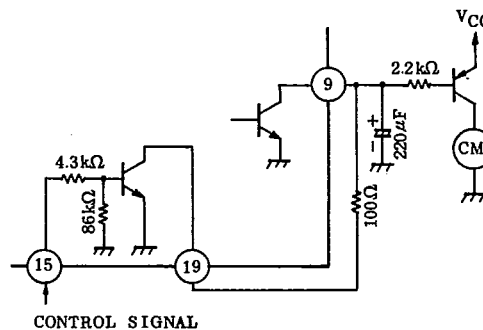

Fig. 6

(6) Thermal Shut Down Circuit

This item includes the mechanism driver circuits. As a mechanical condition causes one motor or more to lock compulsorily, the large current makes the temperature of this chip be up extremely. In result, this causes the leak current of PN-junction increase, then the temperature is up more and more. Finally the thermal run-away takes place at this item. Therefore, the Thermal Shut Down Circuit prevents it from doing thermal run-away. In case that the temperature of chip gets up about 160°C, this circuit cuts off the drivers for RM, CM and Plunger.

(7) Power Consumption

It is necessary to take care the power consumption in this IC, in order to control the large current.

PD expression.

$$P_D = P_D(Q) + P_D(CM) + P_D(PLC)$$

$$P_D(Q) = I_{CCQ} \times V_{CC}$$

$$P_D(RM) = I_{RM} \times (V_{CC} - |V_{14} - V_{12}|)$$

$$P_D(CM) = I_{CM} \times V_{CE(sat. Q11)}$$

$$P_D(PLC) = I_{PLC} \times V_{CE(sat. Q14)}$$

(Note) This P_D is larger at PLAY/High Speed PLAY than at F.F./REW. And this is larger at PLAY than at High Speed PLAY.

$$|V_{14} - V_{12}| \approx V_1 + 0.6V$$

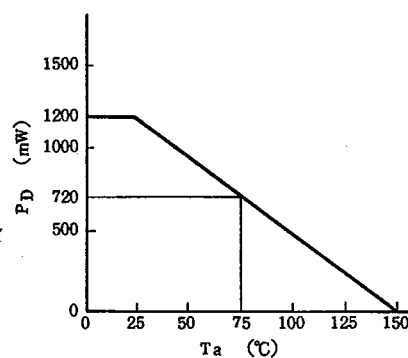

TA7780BN

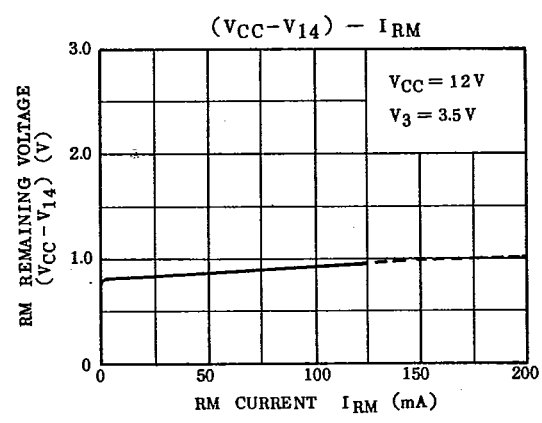
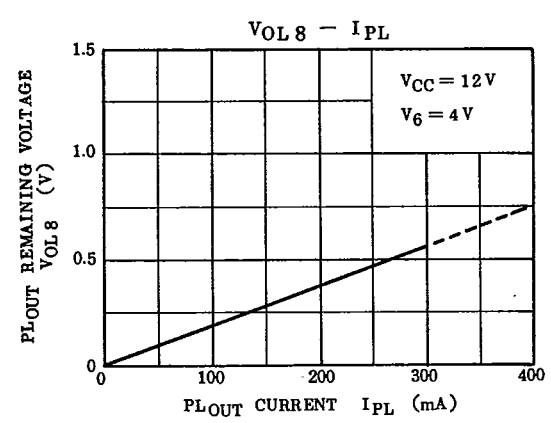
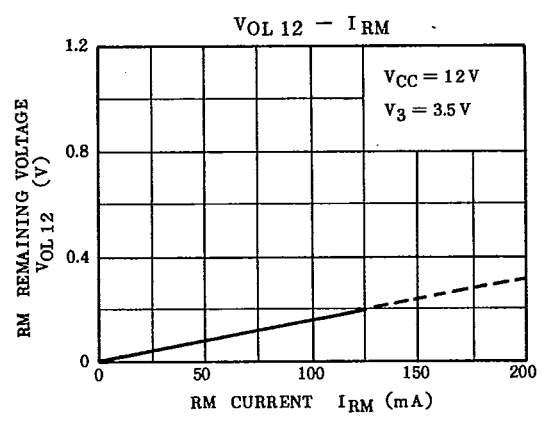
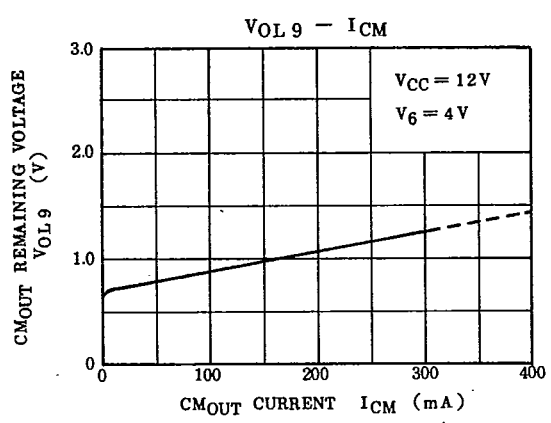
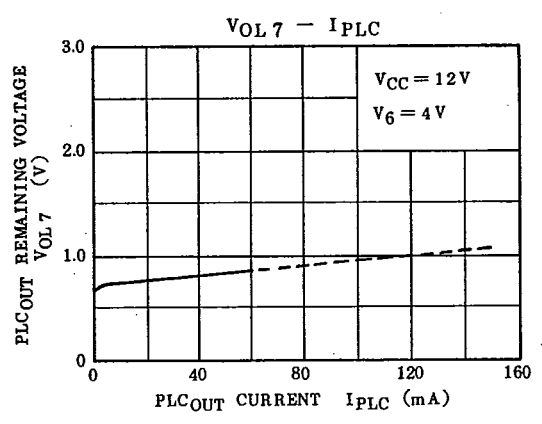
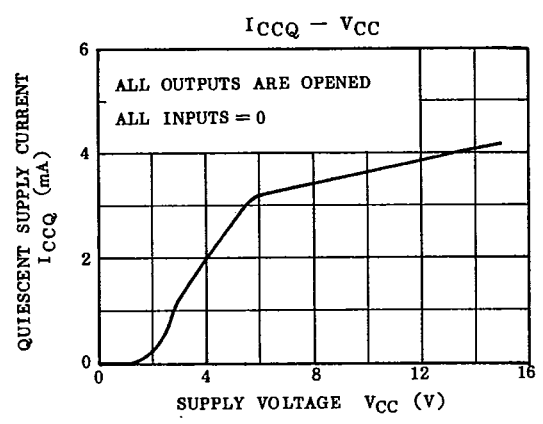

AUDIO LINEAR IC

TA7780BN

