

MOTOROLA SEMICONDUCTOR

TECHNICAL DATA

Product Preview

Chroma 4 Multistandard Video Processor

The MC44001 is a highly advanced circuit which performs most of the basic functions required for a color TV. All of its advanced features are under processor control via an I²C bus, enabling potentiometer controls to be removed completely. In this way the component count may be reduced dramatically, allowing significant cost savings together with the possibility of implementing sophisticated automatic test routines. Using the MC44001, TV manufacturers will be able to build a standard chassis for anywhere in the world.

- Operation from a Single + 5.0 V Supply; Typical Current Consumption Only 120 mA
- Full PAL/SECAM/NTSC capability
- Dual Composite Video or S-VHS Inputs
- All Chroma/Luma Channel Filtering, and Luma Delay Line Are Integrated Using Sampled Data Filters Requiring No External Components
- Filters Automatically Commutate with Change of Standard
- Chroma Delay Line is Realized with a 16 Pin Companion Device, the MC44140
- RGB Drives Incorporate Contrast and Brightness Controls and Auto Gray Scale
- Switched RGB Inputs with Separate Saturation Control
- Auxiliary Y, R-Y, B-Y Inputs
- Line Timebase Featuring H-Phase Control, Time Constant and Switchable Phase Detector Gain
- Vertical Timebase Incorporating Vertical Geometry Corrections
- E-W Parabola Drive Incorporating Horizontal Geometry Corrections
- Beam Current Monitor with Breathing Compensation

MC44001

Chroma 4 VIDEO PROCESSOR

SILICON MONOLITHIC INTEGRATED CIRCUIT

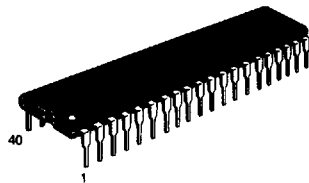

P SUFFIX
PLASTIC PACKAGE
CASE 711

PIN CONNECTIONS

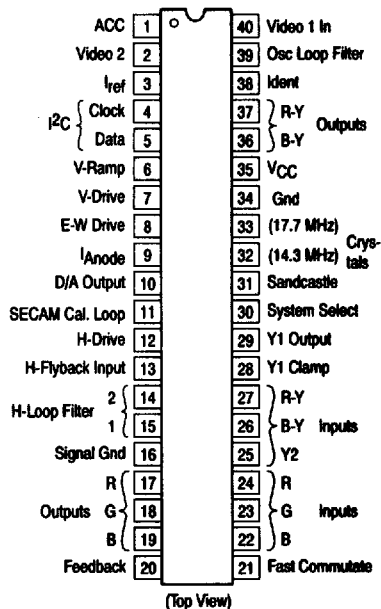

MAXIMUM RATINGS (T_A = 25°C, unless otherwise noted).*

Ratings	Pin	Symbol	Value	Unit
Supply Voltage	35	V _{CC}	6.0	Vdc
Operating Ambient Temperature	35	T _A	0 to +70	°C
Storage Temperature	—	T _{stg}	-65 to +150	°C
Junction Temperature	—	T _J	+150	°C
Drive Output Sink Current	12	I ₁₂	2.0	mA
Applied Voltage Range:				Vdc
E-W Drive	8	V ₈	0 to +7.0	
Feedback	20	V ₂₀	0 to +7.0	
Anode Current	9	V ₉	-2.0 to V _{CC}	
All Other Pins	—	V _i	0 to V _{CC}	

* (Based on C26K, C32K, C63K and C88K geometries characterizations)

ORDERING INFORMATION

Device	Temperature Range	Package
MC44001P	0° to +70°C	Plastic DIP

MC44001

GENERAL DESCRIPTION OF THE CHROMA 4 SYSTEM

Figure 1 shows a simplified block diagram representation of the basic system using the MC44001 and its companion device the MC44140 chroma delay line. The Chroma 4 has been designed to carry out all the processing of video signals, display controls and timebase functions. There are two video inputs which can be used for normal composite video or separate Y and C inputs. In either case, the inputs are interchangeable and selection is made via the I²C bus. The video is decoded within the MC44001 which involves

separation, filtering and delay of the luminance part of the signal, and demodulation of the chroma into color difference signals. The luminance (called Y1) together with the demodulated R-Y and B-Y are all then brought out from the IC. The color difference signals then enter the MC44140 which performs color correction in PAL and the delay line function in SECAM. Corrected color difference signals then re-enter the MC44001.

Figure 1. Connection to TV Chassis

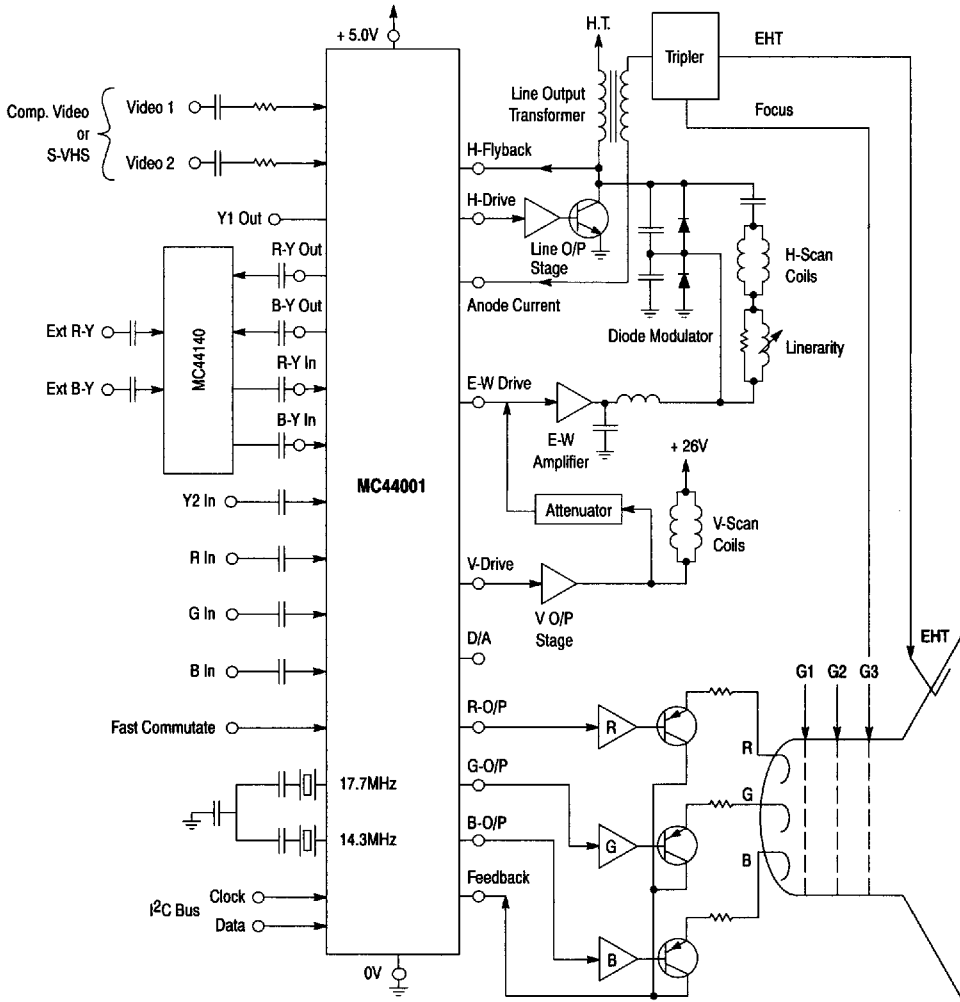

MC44001

The next stage is called the color difference stage where a number of control functions are carried out together with matrixing of the components to derive RGB signals. At this point a number of auxiliary signals may also be switched in, again all under MCU control. External RGB (text) and Fast Commutate enter here; also an external luminance (Y2) may be used instead of Y1. External R-Y and B-Y are switched in via the delay line circuit to save pins on the main device. The Y2 and External R-Y, B-Y will obviously be of considerable benefit from the system point of view for use with either feature boxes MAC or CT1.

The final stage of video processing is the RGB outputs which drive the high voltage amplifiers connected to the tube cathodes. These outputs are controlled by a sophisticated digital servo-loop which is maintained and stabilized by a sequentially sampled beam current feedback system. Automatic gray scale control is featured as a part of this system.

Both horizontal and vertical timebases are incorporated into the MC44001 and control is via the I²C bus. The horizontal timebase employs a dual loop system of a PLL and variable phase shifter, and the vertical uses a countdown system. For the vertical, a field rate sawtooth is available which is used to drive an external power amplifier with flyback generator (usually a single IC). The line output consists of a pulse which drives a conventional line output stage in the normal way. The line flyback pulse is sensed and used by the second loop for horizontal phase shift.

Where E-W correction is required, a parabola waveform is available for this which, with the addition of a power amplifier, can be used with a diode modulator type line output stage for dynamic width and E-W control. The bottom of the EHT overwinding is returned to the MC44001 and is used for anode current monitoring and anti-breathing correction.

A much more detailed description of each stage of the MC44001 will be found in the next section. Information on the delay line is to be found in this data sheet.

Introduction

The following information describes the basic operation of the MC44001 IC together with the MC44140 chroma delay

line. The MC44001 is a highly advanced circuit which performs all the video processing, timebase and display functions needed for a modern color TV. The device employs analog circuitry but with the difference that all its advanced features are under processor control, enabling external filtering and potentiometer adjustments to be removed completely. Sophisticated feedback control techniques have been used throughout the design to ensure stable operating conditions and the absence of drift with age.

The IC described herein is one of a new generation of TV circuits, which make use of a serial data bus to carry out control functions. Its revolutionary design concept permits a level of integration and degree of flexibility never achieved before. The Chroma 4 consists of a single bipolar VLSI chip which uses a high density, high frequency, low voltage process called MOSAIC 1.5. Contained within this single 40 pin package is all the circuitry needed for the video signal processing, horizontal and vertical timebases and CRT display control for today's color TV. Furthermore, all the user controls and manufacturer's set-up adjustments are under the control of the processor I²C bus, eliminating the need for potentiometer controls. Chroma 4 offers an enormous variety of different options configurable in software, to cater to virtually any video standard or circumstance commonly met. The decoder section offers full multistandard capability, able to handle PAL, SECAM and NTSC standards. Practically all the filtering is carried out onboard the IC by means of sampled data filters, and requires no external components or adjustment.

Digital Interface

One of the most important features of Chroma 4 is the use of processor control to replace external potentiometer and filter adjustments. Great flexibility is possible using processor control, as each user can configure the software to suit their individual application. The circuit operates on a bidirectional serial data bus, based on the well known I²C bus. This system is rapidly becoming a world standard for the control of consumer equipment.

MC44001

I²C Bus

It is not within the scope of this data sheet to describe in detail the functioning of the I²C bus. Basically, the I²C bus is a two-wire bidirectional system consisting of a clock and a serial data stream. The write cycle consists of 3 bytes of data and 3 acknowledge bits. The first byte is the Chip Address, the second the Sub-address to identify the location in the memory, and the third byte is the data. When the address' Read/Write bit is high, the second and third bytes are used to transmit status flags back to the MCU.

Figure 2 shows a block diagram of the MC44001 Bus Interface/Decoder. To begin with, the start bit is recognized by means of the data going low during CLK high. This causes the Counter and all the latches to be reset. For a write operation, the Write address (\$88) is read into the Shift Register. If the correct address is identified, the Chip Address Latch is set and at CLK 9 an acknowledge is sent.

The second byte is now read into the Shift Register and is used to select the Sub-address. At CLK 18 a Sub-address Enable is sent to the memory to allow the Data in the register to be changed. Also at CLK 18 another acknowledge is sent.

The third byte is now read into the Shift Register and the Data bussed into the memory. The Data in the Sub-address location already selected is then altered. A third acknowledge is sent at CLK 27 to complete the cycle.

A Read address (\$89) indicates that the MCU wants to read the Chroma 4 status flags. In this instance, the Read/Write Latch is set, causing the Memory Enable and Subaddress Enable to be inhibited, and the flags to be written onto the data line. Two of the status flags are permanently wired one-high and one-low (O.K. and Fault), to provide a check on the communication medium between the MC44001 and the MCU.

At start-up the Counter is automatically reset and the Data for each Sub-address is read in. Only after the entire memory contents has been transmitted, is Data 00 sent to start the Horizontal Drive.

It must be noted that Chroma 4 does not fully conform to the I²C bus specification. The protocol of the Chroma 4 bus differs from that of the I²C bus in the following respect:

When the device is in the Read mode, it starts with the Chip Address as always, but detects the Read bit high and sends an acknowledge (SDA pulled low). The first byte of data is transmitted to the MCU and an acknowledge is also given. The second byte is transmitted, again followed by an acknowledge. These two acknowledges are always transmitted, both in the Read and Write mode. In the I²C bus specification, it is normally the receiver device which provides the acknowledge, in order to indicate the validity of the transmission.

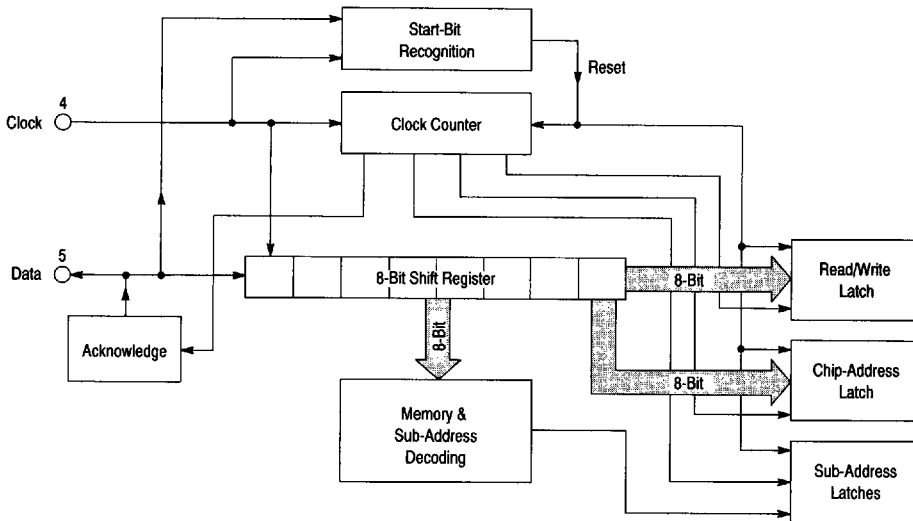
Figure 2. I²C Bus Interface and Decoder

MC44001

Memory

Figure 3 shows a diagram of the MC44001 Memory Map. It has 18 bytes of memory which are located at hex sub-addresses 77 to 88. Sub-address 77 is used to set up the vertical timebase mode of the IC and for S-VHS switching, and consists of 8 separate data bits. The remaining 17 bytes

use the least significant 6-bits as an analog control register. The contents of each are D/A converted, providing an analog control current which is distributed to the appropriate part of the circuit. Bits 6 and 7 are used singularly for switching control functions.

Figure 3. MC44001 Memory Map

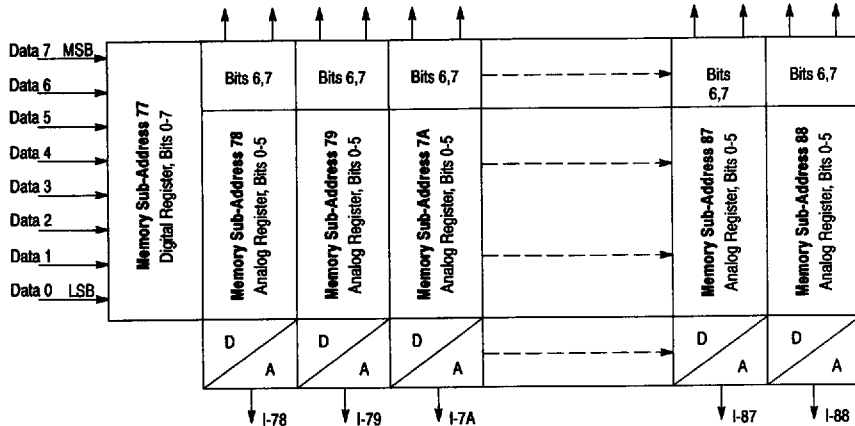
**Chroma Decoder**

The main function of this section is to decode the incoming composite video, which may be in any of the PAL, NTSC or SECAM Standards, and to retrieve the luminance and color difference signals. In addition the signal filtering and luma delay line functions are carried out in this section by means of sampled data filters.

The entire decoder section operates in sampled data mode using clocks generated by external crystals. The oscillator, which is phase-locked in the usual way for PAL/NTSC modes, provides the clock function for the whole circuit. The crystals are selected by the MCU by means of a control bit. Only crystals appropriate to the standards which are going to be received need to be fitted. A 17.7 MHz crystal (4x PAL subcarrier) is used for PAL and SECAM systems (50 Hz, 625 lines); and 14.3 MHz (4x NTSC subcarrier) for the NTSC system (60 Hz, 525 lines). Nearly all the filters, together with the luma delay line and peaking, have been integrated, requiring no external components or any adjustment. The filter characteristics are entirely determined by the clocks and by capacitor ratios, and are thus completely independent of variations in the manufacturing process. The PAL/NTSC subcarrier PLL and ACC loop filters have not been integrated in order to facilitate testing. These filters consist of fixed external components.

Figure 4 is a block diagram of the main features of the chroma decoder. Selection is first made between the V1 and V2 inputs. These may be either normal composite video or separate luma and chroma which may enter the IC at either

pin. Commands from the MCU are used to route the signals through the appropriate delay and filter sections. A composite video signal first passes through the sound trap filter which is of recursive design. With the 17.7 MHz crystal selected the following trap frequencies may be set by an MCU control word: 5.5 MHz, 6.0 MHz, 6.5 MHz. Next, the video enters the luma delay line and SECAM cloche filter. The PAL or NTSC chroma signal is separated out by a transversal filter receiving inputs from taps along the luma delay line, arranged in such a way that group delays in PAL and SECAM are nominally equalized. A second set of taps feeds another transversal filter whose function is to provide a chroma trap combined with luma channel peaking. In SECAM mode the trap frequency is dynamically steered to follow the instantaneous frequency of the chroma.

The high frequency luma may be peaked in 1 dB steps, up to a maximum of +6 dB, by a control word from the MCU. Another control word is used to trim the delay in the luma channel. Five steps of 56 ns are possible, giving a total programmable delay of 280 ns. The resulting processed luma signal then proceeds to the color difference section. The luma output (Y1) is also made available at Pin 29, for use with frame store or other auxiliary function.

As all the delay and filter responses are determined by the clock, they automatically commute to the new standard when the crystal is changed over. Thus, when the 14.3 MHz clock is being used the chroma trap moves to 3.58 MHz, and the sound traps move to 4.5 MHz.

MC44001

The filtered PAL/NTSC and SECAM chroma signals are decoded by their respective circuits. The PAL/NTSC decoder employs a conventional design, using ACC action for gain control and the common double balanced multipliers to retrieve the color difference signals. The SECAM decoder is discussed in a separate subsection.

The identification signals from the PAL and SECAM decoders are set in opposition to each other, this being done as the best way to prevent misidentification between the two. The actual decision as to a signal's identity is made by the MCU based on data provided by 3 flags returned to it, namely: ACC Active, PAL Identified, and SECAM Identified.

This allows a maximum of flexibility, since the software may be written to accommodate many different sets of circumstances. For example, channel information could be taken into account if certain channels always carry signals in the same standard. Alternatively, if one standard is never going to be received, the software can be adapted to this circumstance. If none of the flags are on, color killing will be implemented by the MCU. This occurs if the net Ident Signal is too low, or if the ACC circuit is inactive due to too low a signal level.

The demodulated color difference signals now enter the Saturation/Hue control section, where selection is made between PAL/NTSC and SECAM outputs. The Saturation and Hue control is simply realized by altering the amplitudes of both color difference signals together. Hue control is only a requirement in NTSC mode and would not normally be used for other standards. The function is usually carried out prior to demodulation of the chroma by shifting the phase of the subcarrier reference, causing decoding to take place along different axes. In Chroma 4, Hue control is performed on the already demodulated color difference signals. A proportion of the R-Y signal is added or subtracted to the B-Y signal and vice-versa. This has the same effect as altering the reference phase. If desired, Chroma 4 can apply the Hue control to simple PAL signals.

After manipulation by the Saturation and Hue controls the color difference signals are finally filtered to reduce any remaining subcarrier and multiplier products. Before leaving the chip at Pins 36 and 37, the signals are blanked during line and frame intervals. The 64 μ s chroma delay line is carried out by a companion device, the MC44140.

Figure 4. Chroma Decoder

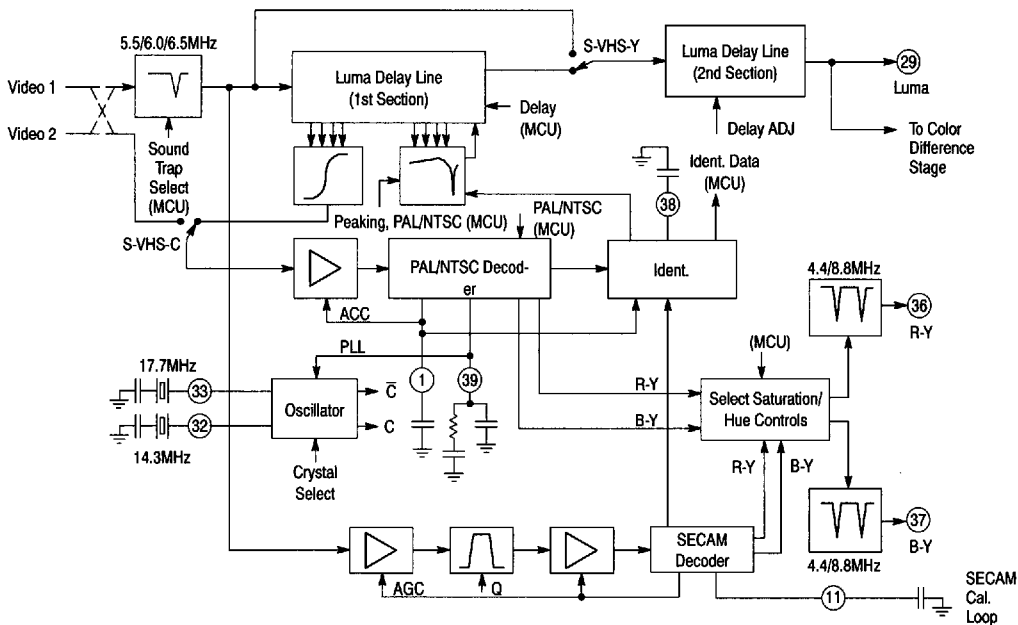

SECAM Decoder

The SECAM signal from the high-pass filter enters tightly controlled AGC amplifiers wrapped around a cloche filter which is a sampled recursive type, with the AGC derived from a signal squarer. Next, the signal is blanked during the calibration gate period and a reference 4.43 MHz is inserted during this time. The SECAM signal is then passed through a limiter.

The frequency demodulator function is carried out by a frequency-locked-loop (F.L.L.). This consists of three components: a tracking filter, a phase detector and a loop filter. The center frequency of the tracking filter depends on

three factors: internal R-C product, ADJUST voltage, TUNING voltage. The tracking filter is dynamically tuned by the TUNING feedback from the loop-filter forming the F.L.L. The ADJUST control calibrates the F.L.L. and compensates for variations in the R-C product. After the F.L.L. the color difference signals are passed to another block where several functions are carried out. The signals are de-emphasized and outputs are provided to the IDENT section. Another function of this section is to generate the ICOMP signal used for calibrating the F.L.L. This signal is blanked during the H-IG period to ensure that (R-Y) and (B-Y) output signals have a clean DC level for clamping purposes.

MC44001

In addition, components are added to compensate for the R-C product, and tuning offsets are introduced during the active lines for FOR/F0B.

Calibration of the F.L.L. takes place during every field blanking interval, starting from field retrace and ending just before the SECAM vertical ident. sequence (bottles). The calibration current I_{CAL} is derived from I_{COMP} during the calibration gate (CAL) and integrated by an external capacitor on Pin 11. The resulting voltage V_{EXT} is then transformed to generate the ADJUST control voltage removing from the loop range most of the variations due to internal RC products and temperature.

Color Difference Stages

This stage accepts luminance and color difference signals, together with external R,G,B and Fast Commutation inputs and carries out various functions on them, including clamping, blanking, switching and matrixing. The outputs, consisting of processed R,G,B signals, are then passed to the Auto Gray Scale section.

A block diagram of this stage is shown in Figure 6. The Y2, R-Y, B-Y together with R, G and B are all external inputs to the chip. The Y1 signal comes from the decoder section. Each of the signals is back-porch clamped and then blanked. The Y2 and R,G,B inputs have their own simple sync separators, the output from which may be used as the primary synchronization for the chip by means of commands from the MCU.

The Fast Commutation is an active high input used to drive a high speed switch; for switching between the Y and color difference inputs and the R,G,B (text) inputs.

After blanking, the Y1 and Y2 channels go to the Luma Selector which is controlled by means of 2-bits from the MCU. From here the selected luma signal goes to the RGB matrix. The two color difference signals pass through a second saturation control, whose main function is described later. From here they go to a matrix in which G-Y is generated from the R-Y and B-Y, and lastly, to another matrix where Y is added to the three color difference signals to derive R,G,B.

The R,G,B inputs may take one of two different paths. They may either go straight to the output without further processing, or via a separate matrix and the second saturation control. The path taken is controlled in software. When the latter route is selected, the R,G,B signals undergo a matrix operation to derive Y. From this R-Y and B-Y are easily derived by subtraction from R and B; the derived color difference signals are then subjected to saturation control. The second saturation control may be disabled by the MCU if desired. This extra circuitry allows another feature to be added to the TV set, namely the ability to adjust the color saturation of the RGB inputs. This is not possible on present day receivers. After the saturation control the derived signals are processed as before.

Figure 5. SECAM Decoder

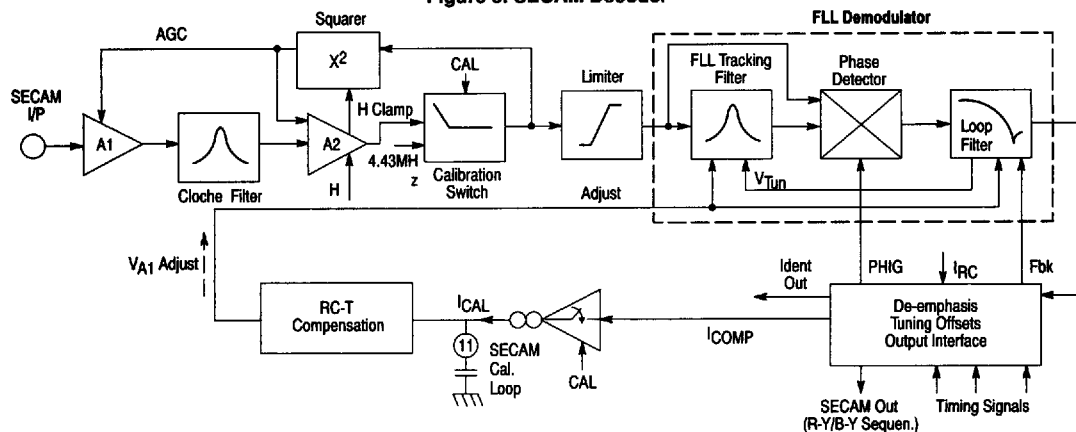

MC44001

Figure 6. Color Difference Stages

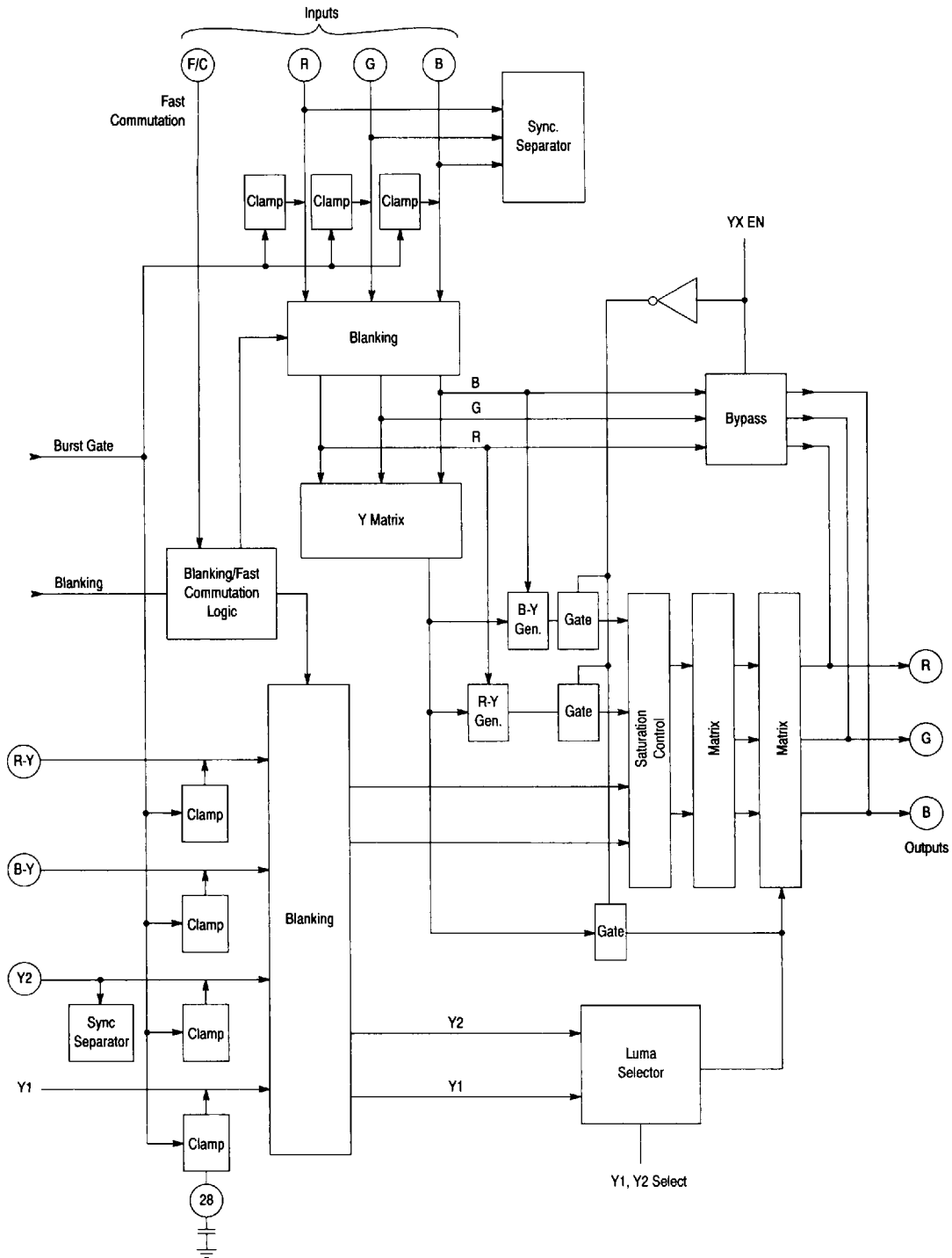

MC44001

Auto Gray Scale Control Loops

This section supplies current drives to the RGB cathode amplifiers and receives a signal feedback from them, proportional to the combined cathode currents. The current feedback is used to establish a set of feedback loops to control the DC and gain of the RGB drives. There are three loops to control the dark currents and another three to control the gains. During the field blanking period the video outputs are switched off and a set of references are inserted on three consecutive lines to control the R, G, and B outputs respectively. The white current reference pulses are sent first, followed by the black current reference pulses. Drives whose outputs are not being monitored are rendered nonconducting during this time.

A block diagram of the complete system is illustrated in Figure 7. Data words from the MCU which represent the RGB color temperatures selected at the factory, are stored in Latches 1,2,3 and D/A converted by DAC1,2,3 to reference currents. During, e.g., the red dark current set-up period, the reference current from DAC1 is selected and compared with the feedback current. The currents must match each other. If not, a current will flow in resistor R producing an error voltage. This is then buffered into comparators Comp1, 2 and is compared with voltage references Vref1 and Vref2. If the error voltage is greater than Vref1, Comp1 causes the counter to count up. If the error voltage is less than Vref2, Comp2 sends a count-down command. In this way a "deadband" is set up to prevent the outputs from continuously changing.

During Load the contents of the counter are loaded into Latch 6 (for red DC) and then D/A converted by DAC6. The resulting DC current is then applied as an offset to the red output amplifier, completing the loop. For white current set-up the same color temperature data is used but multiplied by a common factor. A common pulse representing a white level is applied to the RGB cathode amplifiers. The feedback loop adjusts the gains to establish a set of cathode currents scaled by a common factor to a set of black currents. Therefore, the image color will always be adjusted to match the black level color; i.e. gray scale tracking is ensured.

The Load/Backload sequencer is used to control which latch is being addressed at any given time by means of the timing signals input to it. The backload command sends the data from the appropriate latch to the Up/Down Counter, ready to be modified if necessary.

The Brightness control is affected by simply changing the DC pedestal of all three drives by the same amount, and does not form part of the feedback loop. The Contrast is adjusted to a set of values dependent on the level of the input pulse applied during the calibration time. This level is set by a control word from the MCU. Once the loops have stabilized under normal working conditions, they may be deactivated by means of a control bit from the MCU. When, however, any change is made to either contrast or brightness, the loops must be reactivated.

An extra loop has been included via Latch 4 and DAC 4, which operates during the field flyback time to compensate for offsets within the loop. This has the effect of counteracting any input offset from the Buffer/Amp and will also compensate for cathode leakage should this be needed.

A second output of the reference currents from DAC6, 8 and 10 are used to compare with preset limits, to ensure that

the loops are working within their range of control. Should the limits be exceeded in either direction, flags are returned to the MCU to request that the G2 control be adjusted up or down as appropriate.

Horizontal Timebase

The horizontal timebase consists of a PLL which locks up to the incoming horizontal sync, and a phase detector and shifter whose purpose is to maintain the H-Drive in phase with the line flyback pulse.

Because of on-chip component tolerances, the free-running oscillator frequency cannot be set more accurately than $\pm 40\%$; whereas $\pm 5\%$ would be a more appropriate figure for the sake of the line output stage. For this reason the free-running frequency is calibrated periodically by other means. Continuously during start-up and thence during two lines every field, the phase detector is disconnected from the VCO. A block diagram of the line timebase is given in Figure 8. The calibration loop consists of a frequency comparator driving an Up/Down Counter. The count is D/A converted to give a DC bias which is used to correct a 1.0 MHz VCO. The 1.0 MHz is divided by 64 to give line frequency and this is returned to the frequency comparator. This compares Fh from the VCO with a reference derived from dividing down the subcarrier frequency. Any difference in frequency will result in an output from the comparator, causing the counter to count up or down; and thus closing the loop.

A Coincidence Detector looks at the PLL Fh and compares it with the incoming H-sync. If they are not in lock, a flag is returned to the MCU. To allow for use with VCRs, the gain of the phase detector and the loop time constant may be switched by means of commands from the MCU.

Twice line frequency is output from the PLL which may be divided by either 1 or 2 depending on the command of the MCU. The x2 Fh will be used with Frame Store TV in the future. The phase of the Fh and flyback pulses are compared in a phase detector, whose output drives a phase shifter. A 6-bit control word and D/A converter are used to apply an offset to the phase detector giving a horizontal phase shift control. Also the phase of the horizontal drive may be shifted by 180 degrees with a control bit set by the MCU.

The presence of the horizontal flyback pulse is detected; if it is missing a warning flag is sent back to the MCU which can take appropriate action.

Vertical Timebase

The vertical timebase consists of two sections; a digital section which includes a vertical sync separator and standard recognition; and an analog section which generates a vertical ramp which may be modified under MCU control to allow for geometrical adjustments. A parabola is also generated and may be used for pin-cushion (E-W) correction and width control (see Figure 9).

The MC44001 uses a video sync separator which works using feedback, such that the threshold level of a comparator (slice level) is always maintained at the center of the sync pulse. Sync from any of the auxiliary inputs may also be used. The composite sync is fed to a vertical sync separator, where vertical sync is derived. This consists of a comparator,

MC44001

up/down counter and decoder. The counter counts up when sync is high, and down when sync is low. The output of the decoder is compared with a threshold level, the threshold only being reached with a high count during the broad pulses in the field interval.

Initially the vertical timebase operates in Injection Lock mode, until a standard signal is recognized (525, 625), then it is switched to a Countdown mode. A standard recognition circuit is employed, which looks for a count of more or less than 576; the standard recognized is then indicated to the MCU. Commands from the processor may be used to force the timebase to operate only in Countdown mode at 525 or 625 lines, or stay in Injection Locked mode.

An adjustable current source is used to charge an external capacitor at Pin 6 to generate a vertical ramp. The amplitude of the ramp is varied according to the current source (Height), and is automatically adapted when the 525 standard is recognized by multiplying by 1.2. The Linearity control is achieved by squaring the ramp and either adding or subtracting a portion of it to the main linear current.

The final ramp with corrections added is then passed to a driver/amplifier and is output at Pin 7. The vertical ramp can be used to drive a separate vertical deflection power circuit with local feedback control. Vertical "S" Correction will then be made using fixed components within the feedback loop of the power op amp.

The reference ramp is squared to provide a pin-cushion correction parabola, developed across an external resistor at Pin 8. The parabola amplitude may be varied from zero to a maximum level set by the external resistor. The parabola itself is squared, giving an independent fourth order term (Corner Correction) whose level can also be varied; this is then added as a further modifying term to the E-W output. This latter correction is used for obtaining good corner geometry with flat-square tubes. A variable DC current is added to the parabola to effect a width control. Using a suitable power amplifier and a diode-modulator in the line output stage, the parabola may be used for E-W correction and dynamic width control. A further control is provided to shift the center point of the parabola up and down the screen (Parabola Tilt), to accommodate different CRTs. As with the vertical ramp output, an EHT correction is applied.

All of the vertical and horizontal signals are adjustable via 6-bit words from the MCU, and stored in latches. The adjustment controls available are:

Vertical Amplitude/Linearity/Breathing Correction
Parabola (E-W) Amplitude/Horizontal Amplitude/
Corner Correction, and Parabola Tilt

The Anode Current Sense at Pin 9 is also used as a beam current monitor. Two thresholds may be set, by the manufacturer, using external components. The first threshold sets a flag to the processor if beam current becomes excessive. The MCU could e.g. reduce brightness and/or contrast to alleviate the condition. The second threshold sets a flag warning of an overload condition where the CRT phosphor could be damaged. If such a condition were to arise, the processor would be programmed to shut down the PSU.

The vertical blanking period may be selected by means of a bit from the MCU to either 22 or 11 lines. The interlace may also be suppressed again under the control of the processor.

Vertical Countdown System

The MC44001 uses a countdown system to implement the vertical timebase function. Initially, the vertical timebase should reset to the Injection mode. This means that the timebase locks immediately to the first signal received, in exactly the same way as an old type injection locked timebase. A Coincidence Detector looks for counts of the right number (e.g., 625) and causes a 4-bit counter to count up. When there are 8 consecutive coincidences the vertical countdown is engaged, and the MSB of the counter is brought out to the set flag. Then the Auto Countdown mode should be set. Similarly, non-coincidences which will occur if synchronizing pulses are missing or in the wrong place, or if there is noise on the signals, cause the counter to count down. When the count goes back to zero, after 8 non-coincidences, the timebase automatically reverts to Injection Lock mode.

If it is known that lock will be lost (e.g., channel change), it is possible to jump straight into Injection Lock mode and not have to wait for the 8 consecutive non-coincidences. In this way the new channel will be captured rapidly. Once locked on to the new channel, "auto countdown" is then reselected by the MCU.

Under some conditions such as some VCRs in Search mode, it is possible to get signals having an incorrect number of lines, meaning that the countdown flag will go off because of successive non-coincidences. In these circumstances, if "auto countdown" is selected, the timebase will automatically lock to the signal in the Injection Lock mode. The fact that the flag is effectively saying that the vertical timebase is out of lock need not be a cause for major concern, since the horizontal timebase will still be locked to the signal, and has its own flag — "Horizontal out of lock". The vertical countdown and horizontal lock flags both perform an independent test for the presence of a valid signal. A logical OR function can be performed on the two flags, such that if either are present then by definition a valid signal is present.

The vertical oscillator has end-stops set at two line-count decodes as given below:

$$50 \times 625 / 672 = 46.5 \text{ Hz (min)}$$

$$50 \times 625 / 512 = 61.0 \text{ Hz (max)}$$

These figures assume that the horizontal timebase is running at 15,625 Hz. When the vertical timebase is in Injection Lock mode the line counter reset is inhibited so that it ignores any sync pulses before a count of 512 is reached. This prevents any possible attempted synchronization in the middle of the picture. If the count reaches 672 lines then there is an automatic reset which effectively sets the lower frequency limit. The choice of these limits is a compromise between a wide window for rapid signal capture and a narrow window for good noise immunity.

It is also possible to run the timebase in 2V mode as there are decodes for 100 Hz (2 x 50 Hz) operation with upper and lower limits in proportion. This is, of course, intended to be used in conjunction with field and frame memory stores. The similar decodes which would be necessary to allow 120 Hz (2 x 60 Hz) operation have not, for the present, been implemented. Finally, the timebase can be forced into a count of either 625 or 525 by commands from the MCU; in this mode the input signal, if present, is ignored completely. If there is no signal present save for noise, then this feature can be used to obtain a stable raster.

MC44001

Figure 7. Auto Gray Scale Control Loops

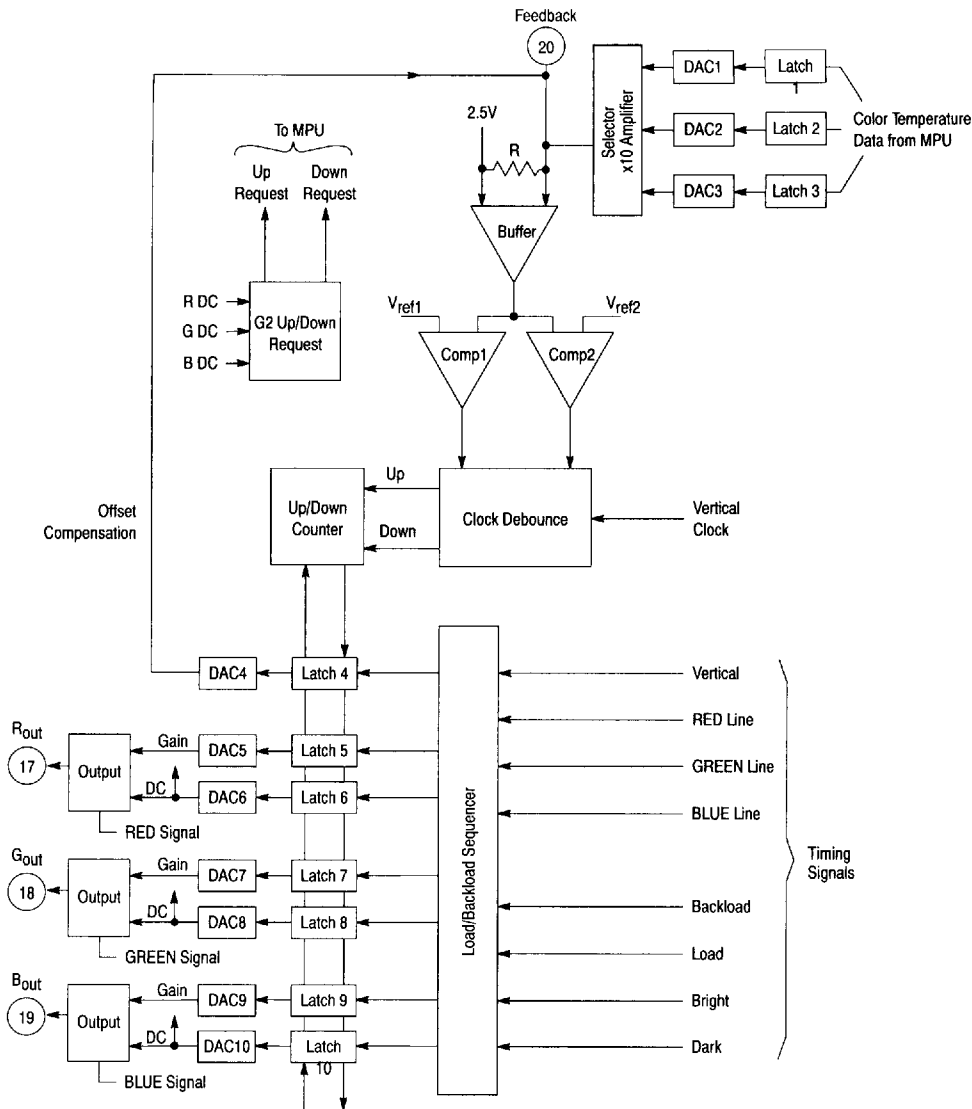

PIN FUNCTION AND EXTERNAL CIRCUIT REQUIREMENTS

The following section describes the purpose and function of each of the 40 pins on the MC44001. There is also an explanation of the external circuit component requirements for a practical application; a diagram of the small signal circuit will be found in Figure 10. One of the primary design aims for the MC44001 was to use the minimum number of external components, and where these are necessary to employ low cost and easily obtainable standard types. Thus for example, as all the video signal filtering is carried out on the IC there are no coils required whatsoever. The most common requirement is for AC coupling capacitors which are far too

big to be integrated onto the chip. The time constants on certain pins are deliberately left as external components to facilitate testing and for fine tuning the performance.

ACC (Pin 1) – External filter used by ACC section. Normally a single 100 nF capacitor.

Video Inputs 1, 2 (Pin 2, 40) – Video inputs intended for a nominal 1.0 Vp-p input level of composite video. Separate Luma and Chroma components may also be used with these input pins. The external circuit requirement is for a series 100 nF and 1.0 kΩ. The input selection and adaptation for Y and C is carried out in software.

MC44001

Reference Current (Pin 3) – Master reference current used throughout the IC. This is programmed by means of an external pull-up resistor, as onboard resistors are not sufficiently accurate. The designated current is 70 μ A. This pin should be very well decoupled to ground to avoid picking up interference from the nearby I²C bus inputs.

I²C Clock (Pin 4) – I²C bus clock input. This input can be taken straight into the IC, but in a real TV application it may be prudent to fit a series current limiting resistor nearby the pin in case of flashover.

I²C Data (Pin 5) – I²C data input. The comment above for Pin 4 also applies to this pin.

Vertical Ramp (Pin 6) – A current is used to charge an external capacitor connected to this pin, developing a voltage sawtooth with a field period.

Vertical Drive (Pin 7) – The sawtooth derived on Pin 6 is used to drive an external power amplifier vertical output stage. The amplitude and linearity of the output ramp are adjustable via the MCU.

Parabola (E-W) Drive (Pin 8) – A parabolic waveform derived by squaring the vertical ramp is used to drive an external power amplifier. In sets fitted with a diode modulator type line output stage, this provides Width Control and Pin Cushion Correction. The parabola is squared again to give a fourth order correction term required for flat square tubes. The E-W amplitude, DC level, Tilt and Corner Correction are all adjustable by means of the MCU. This is a current output and requires an external pull-up resistor to develop the voltage waveform.

Anode Current (Pin 9) – Used as an anode current monitor whose purpose it is to: provide EHT compensation (antibreathing); and also warn of excessive and overload beam current conditions.

This pin is connected via 560 k series resistor to the bottom of the EHT overwinding. Thus increasing beam current will pull the voltage on this pin more negative. This change is sensed within the chip and used to apply a correction to the ramp and parabola amplitudes. With large beam currents, thresholds at +1 V_{be} and – 2 V_{be} set off warning flags to the MCU, which then has to take the appropriate action. The anode current levels at which these thresholds are reached are set up using fixed external resistors.

Grid 2 Control (Pin 10) – This consists of one of the MC44001 control registers which has been D/A converted and brought out from the IC as a current source. The current may be varied from 0 μ A to 300 μ A, and may be used for a number of auxiliary tasks, such as for Grid 2 control.

SECAM Calibration Loop (Pin 11) – A 100 nF capacitor on this pin is used for the SECAM Calibration Loop.

H-Drive (Pin 12) – Horizontal drive pulses having an approximately even mark-to-space ratio emerge from this pin. This is an open-collector output which can sink up to 10 mA. However, taking this much current is not recommended since

there is no separate ground pin available which may be connected near the line O/P stage; noise could be injected into the signal ground on the IC. Therefore, with a transformer driven line output stage, this output has been designed to be used with an extra external transistor inverter between the IC and the line driver.

H-Flyback Input (Pin 13) – Flyback sensing input taken from the line output transformer. These pulses are used by the 2nd horizontal loop for H-phase control. A positive going pulse from 0 V to + 5.0 V amplitude is needed for correct operation. The internal impedance of the pin is about 50 k Ω . An external attenuating series resistor will also be needed.

H-Loop 2 Filter (Pin 14) – A simple external filter consisting of a 100 nF capacitor for the 2nd horizontal loop.

H-Loop 1 Filter (Pin 15) – Horizontal PLL loop time constant. The value of RC time constant is selected with external components to give a smooth recovery after the field interval disturbance.

Signal Ground (Pin 16)

R,G,B Outputs (Pin 17, 18, 19) – The R,G,B drives are current rather than voltage due to the limited headroom available with the 5.0 V supply line. The outputs themselves consist of open-collector transistors and these are used to drive the virtual ground point of the high voltage cathode amplifiers.

Feedback (Pin 20) – Current feedback sense derived from the video output amplifiers. The currents from all three guns are summed together as each is driven sequentially with known current pulses during the field interval. This feedback is then compared with internally set-up references. A low value ceramic capacitor to ground may be fitted close to this pin to help stabilize the control loops.

A secondary function of this pin is for peak beam current limiting. When the feedback voltage during picture time becomes too great (i.e., too high beam current), a threshold at V_{CC} + 2 V_{be} is exceeded at which time a flag is sent to the MCU. The MCU then has to carry out the function of peak beam limiter by e.g. reducing contrast until the flag goes off. The threshold current is set externally with a fixed resistor value.

Fast Commutate (Pin 21) – A very fast active high switch (transition time 10 ns). Used with text on the R,G,B inputs, for overlaying text on picture. This hardware switch may be enabled and disabled in software.

R,G,B Inputs (Pins 22, 23, 24) – These external input signals are AC coupled into the IC via 100 nF capacitors and are clamped. The inputs have a 1.0 k Ω impedance and should be driven with 700 mVp-p signal levels.

Y2 Input (Pin 25) – Auxiliary external input to the MC44001. The pin has a 1.0 k Ω impedance and should be driven with 700 mVp-p of luminance signal. The signal must be AC coupled via an external 100 nF coupling capacitor, and is clamped internally.

MC44001

B-Y and R-Y Inputs (Pin 26, 27) – Corrected color difference inputs from the MC44140. The signals are AC coupled to the MC44001 color difference section and are clamped. The input impedance is of the order of 1.0 k Ω .

Y1 Clamp (Pin 28) – External capacitor used by the circuit which clamps the Y1 signal output on Pin 29.

Y1 Output (Pin 29) – The luminance, after passing through the filter and delay line/peaking sections, is made available on this pin.

System Select (Pin 30) – A DC level output controlled in software. Used by the MC44140 for system selection.

Sandcastle (Pin 31) – A special timing pulse derived in the MC44001 for use by the MC44140.

Crystal (Pin 32, 33) – A 14.3 MHz crystal is required at Pin 32 for NTSC decoding, and a 17.7 MHz crystal is required at Pin 33 for PAL and SECAM decoding. Either crystal may be omitted if the application does not involve the associated signals. The appropriate crystal is selected by the MCU.

The crystals are parallel-driven, and require an external load capacitor of 20 pF to 30 pF. *Only crystals intended for VCO operation should be used.* The selected crystal's frequency is made available to the MC44140 by means of the external capacitor divider.

+ 5.0 V Supply (Pin 35) – Supply line, nominally + 5.0 V requiring about 120 mA. The actual voltage should be in the range of 4.75 V to 5.25 V for usable results. It is recommended to decouple the supply line using a small ceramic capacitor mounted close to the supply and ground pins.

Ground (Pin 34)

B-Y and R-Y Outputs (Pin 36, 37) – Demodulated color difference outputs. These signals are AC coupled to the MC44140 for correction and delay with PAL and SECAM, respectively. Signal levels up to a maximum of 1.0 Vp-p may be expected.

Ident (Pin 38) – External filter used by R-Y indent circuit. The filter normally consists of a single capacitor (47 nF) whose value is a compromise between rapid identification and noise rejection.

OSC Loop Filter (Pin 39) – External time constant for chroma PLL. The crystal reference oscillator is phase-locked to the incoming burst in PAL and NTSC. A low value ceramic capacitor, for good noise immunity, is normally placed in parallel with a much longer RC time constant. The PLL pull-in range is reduced when the time constant on the pin is made bigger; allowing this function to be optimized by the user.

CONTROL FUNCTIONS

General Description

As already related in the circuit description, the MC44001 has a memory of 18 bytes. All, except Sub-address 77 and 7F, use the 6 least significant bits (64 steps) as an analog control register with D/A converters within the memory section. The remaining bits are controlled individually for switching of numerous functions. Table 1 gives a listing of all the memory registers and control bits. An explanation of the function of the 16 analog control registers is given below.

Vertical Amplitude – Changes the amplitude of the vertical ramp available on Pin 7.

Vertical Breathing Correction – A correction is applied to the vertical ramp amplitude in a sense opposite to the picture expansion and contraction produced by changes in beam current. This register alters the sensitivity of the beam current sensing and hence the size of correction applied for a given change in beam current.

Parabola Amplitude – Changes the amplitude of the E-W output parabola developed across an external pull-up resistor at Pin 8.

Parabola Tilt – Shifts the point of inflection of the E-W parabola from side to side along the time axis. Also known as *keystone correction*.

Vertical Linearity – The vertical ramp is multiplied by itself to give a squared term, a part of which is either added or subtracted to the linear ramp as determined by this register.

Corner Correction – An independent 4th order term which is subtracted from the E-W parabola to achieve correct geometry with flat square tubes.

Horizontal Amplitude – A variable DC offset applied to the E-W output parabola on Pin 8.

D/A Output – A variable DC current output which may be used to drive auxiliary external circuitry under I²C bus control.

Horizontal Phase Control – Applies a variable phase offset to the horizontal drive pulse at Pin 15 providing for a picture centering control.

B, G, R Temperature – These controls set up the current reference pulses used when sampling the beam current during field interval. The data is fixed by the TV manufacturer when setting up the CRT for correct Gray Scale tracking.

(All the above registers are for use during the test and setting up procedures; the remaining 4 registers are also user controls.)

Contrast – During bright sample time during the field interval this control varies the level of the current pulses injected into the R,G,B channels, so altering the picture contrast.

Brightness – A variable current pedestal which is added to the three drives during active picture time.

Saturation – A variable gain control for the two color difference signals (0 to 140%). There are two such controls within the MC44001, and this control acts on them both.

MC44001

Table 1. Control Data

HEX Sub-address	MSB		Data Byte					LSB
	S-VHS Y	S-VHS C	FSI	BAI	ICI	IFI	CBI	
77	S-VHS Y	S-VHS C	FSI	BAI	ICI	IFI	CBI	CAI
78	INTSEL	CALKILL	Vertical Amplitude					
79	HI	VI	Vertical Breathing Correction					
7A	XS	SSD	Parabola Amplitude					
7B	T1	T2	Parabola Tilt					
7C	SSC	SSA	Vertical Linearity					
7D	P1	SSB	Corner Correction					
7E	P3	P2	Horizontal Amplitude					
7F	D3	D1	Reserved					
80	D EN	D2	D/A Output					
81	Y2 EN	Y1 EN	Horizontal Phase Control					
82	TEST	YX EN	Blue Temperature					
83	Not Used	VCR	Green Temperature					
84	FILT	NORM	Red Temperature					
85	BRI EN	2x Fh	Contrast					
86	SSE	H EN	Brightness					
87	SS1	SAT2 EN	Saturation					
88	V1/V2	SS2	Hue					
00			Dummy - If H EN, then starts H timebase					
FF			Dummy - Resets peak beam limit flag					



Comp. Video/S-VHS Switching
(0 = normal; 1 = S-VHS)

50 Hz/100 Hz Field Rate
Number of Blanked Lines
(Either 22 or 11)

ICI	IFI	Field Scan
0	X	Interlaced
1	0	Even 1/2 Line
1	1	Odd 1/2 Line

CAI	CBI	Vertical Mode
0	0	Force 625
0	1	Force 525
1	0	Inject. Lock
1	1	Auto Count.

HI	VI	SECAM Ident.
0	0	H + V
0	1	H only
1	0	V only
1	1	None

T1	T2	Trap (4.4S/C)
0	0	6.5 MHz
0	1	Not Used
1	0	6.0 MHz
1	1	5.5 MHz

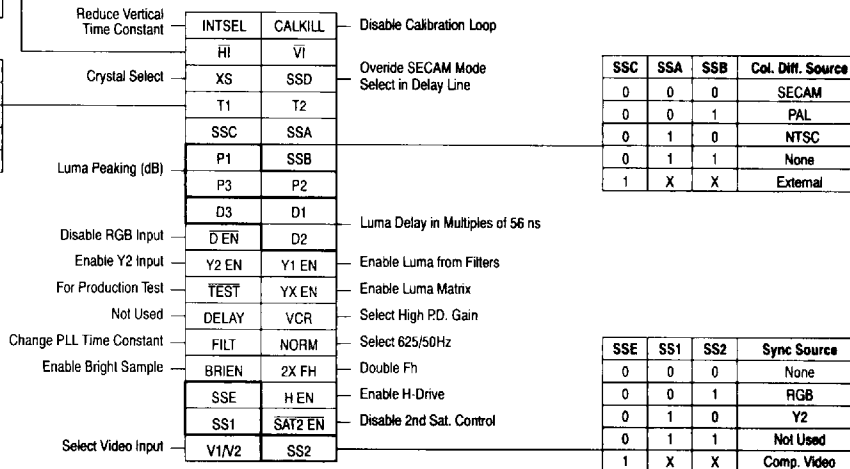

MC44001

Table 2. Control Bit Truth Tables

CAI	CBI	Sync Mode
0	0	Force 625
0	1	Force 525
1	0	Injection Lock
1	1	Auto Countdown

HI	VI	SECAM Ident.
0	0	H + V
0	1	H only
1	0	V only
1	1	None

ICI	IFI	Field Scan
0	X	Interlaced
1	0	Even Up 1/2 Line
1	1	Odd Up 1/2 Line

T1	T2	Trap*
0	0	6.5 MHz
0	1	Not Used
1	0	6.0 MHz
1	1	5.5 MHz

SSC	SSA	SSB	Col. Diff. Source
0	0	0	SECAM
0	0	1	PAL
0	1	0	NTSC
0	1	1	None
1	X	X	External

SSE	SS1	SS2	Sync Source
0	0	0	None
0	0	1	RGB
0	1	0	Y2
0	1	1	Not Used
1	X	X	Comp. Video

P2	P1	P3	Luma Peak (dB) @ 3.0 MHz *
0	0	0	8.5
0	0	1	8.0
0	1	0	7.2
0	1	1	6.3
1	0	0	5.4
1	0	1	3.8
1	1	0	2.3
1	1	1	0.0

D1	D2	D3	Approx. Luma Delay (ns)*
0	0	0	525
0	0	1	581
0	1	0	637
0	1	1	693
1	0	0	749
1	0	1	805
1	1	0	749
1	1	1	805

*Values given with 17.7 MHz crystal selected. Frequencies and delay step size change proportionately when the 14.3 MHz crystal is selected.

SSE, SS1, SS2 – These 3 bits select the signal input from which the timebase synchronization is taken. The composite video input has a high quality sync separator which has been designed to cope with noise and interference on the video; the RGB and Y2 inputs have simple single sync separators which may also be used for synchronization.

T1, T2 – To select the center frequency of the sound trap. Either 5.5 MHz, 6.0 MHz, or 6.5 MHz center frequencies are available.

P1, P2, P3 – These 3 bits are used to adjust the luma peaking value.

D1, D2, D3 – These 3 bits are used to adjust the luma delay value.

The remaining control bits are used singularly and are listed as follows:

S-VHS Y – Selects between luminance from chroma trap/peaking section, and separate luminance which bypasses this filter section.

S-VHS C – In one mode selects chrominance from the takeoff filter which forms part of the luma delay line. The other mode accepts separate chrominance directly for the input.

FSI – Selects either 50 Hz or 100 Hz field rate. When bit is low 50 Hz operation is selected. Not usable with NTSC.

BAI – Either 22 or 11 lines may be blanked using this bit.

INTSEL – The vertical sync separator operates by starting a counter counting up at the beginning of each sync pulse, a field pulse being recognized only if the counter counts up to a sufficiently high value. The control bit INTSEL is used in taking the decision as to when a vertical sync pulse has been detected. When low, the pulse is detected after 8.0 μ s; when high after 24 μ s. This may find application with anti-copy techniques used with some VCRs, which rely on a modified or corrupted field sync to allow a TV with a short time constant to display a stable picture. However, a VCR having a longer time constant will be unable to lock to the vertical.

MC44001

CALKILL – Enables or disables the horizontal calibration loop. The loop may be disabled so long as the horizontal timebase is locked to an incoming signal.

XS – Is used to change between the two external crystal positions (Pins 32 and 33).

SSD – Can be used to override SECAM mode in the delay line. When low, SECAM mode is enabled.

D EN – Enables or disables the RGB Fast Commutation switch for the RGB inputs. When low, RGB inputs are enabled.

Y1 EN – Switches Y1 through to the color difference stage.

Y2 EN – Switches Y2 through to the color difference stage.

Test – When bit is low, enables continuous sampling by the RGB output control loops throughout the entire field period. Used only for testing the IC.

YX EN – Enables the luma matrix when the 2nd saturation control is selected. Used in conjunction with SAT2 EN.

VCR – Is used to change the gain of the horizontal phase detector, e.g., when locking onto a new channel and operation with VCR.

FILT – Controls the time constant of the horizontal PLL. The long time constant is useful for VCR or other non-broadcast quality signals.

Norm – Alters the division ratio for the reference frequency used by the horizontal calibration loop. Always used when changing between 14.3 MHz and 17.7 MHz crystals.

BRI EN – Used to switch on or off the "bright" sampling pulses used by the RGB output loops. This feature was originally introduced to prevent any backscatter from these three bright lines in the field interval from getting into the picture. Must be enabled when adjusting to any of Contrast or Red, Green and Blue color temperatures.

2x Fh – Line drive output is either standard 15.625 kHz (15.750 kHz) or at double this rate.

H EN – Control bit enables horizontal drive pulse. This is normally done automatically after the values stored in the MCU nonvolatile memory have been read into the MC44001 memory.

SAT2 EN – When low enables operation of 2nd saturation control. Used in conjunction with YX EN.

V1/V2 – To select between Video Inputs 1 and 2.

Table 3. Control Bit Functions

Bits	Bit Low	Bit High
V1/V2	Video I/P 2 Selected	Video I/P 1 Selected
SAT2 EN	Second SAT Control Enabled	Second SAT Control Disabled
H EN	H-Drive Enabled	H-Drive Disabled
2x FH	H-Drive: 1X Fh	H-Drive: 2x Fh
BRI EN	"Bright" Sample Switched Off	"Bright" Sample Switched On
Norm	625/50 Hz	525/60 Hz
FILT	H Phase Detector Short Time Constant	H Phase Detector Long Time Constant
VCR	Low H Phase Detector Gain	High H Phase Detector Gain
YX EN	Disable Luma Matrix (2nd SAT Control)	Enable Luma Matrix (2nd SAT Control)
Test	Video O/Ps Sampled Continuously	Video O/Ps Sampled Once Per Field
Y1 EN	Luma From Filters Switched Off	Luma From Filters Switched On
Y2 EN	EXT Luma Input Switched Off	EXT Luma Input Switched On
D EN	RGB Inputs Enabled	RGB Inputs Disabled
SSD	SECAM Mode Select Enabled	SECAM Mode Select Disabled
XS	Pin 33 Crystal Selected	Pin 32 Crystal Selected
CALKILL	H Calibration Loop Enabled	H Calibration Loop Disabled
INTSEL	Fast Vertical Time Constant Selected	Slow Vertical Time Constant Selected
BAI	22 Blanked Lines Selected	11 Blanked Lines Selected
FSI	50 Hz Field Rate Selected	100 Hz Field Rate Selected
S-VHS G	Chroma From Take Off Filter Selected	Direct Chroma From I/P Selected
S-VHS Y	Luma From Notch/Peak Delay Selected	Luma By Passing Notch/Peak Delay

MC44001

FLAGS RETURNED BY THE MC44001

When the Address Read/Write bit is high the last two bytes of I²C data are read by the MCU as status flags; a listing of these may be found in Table 4. The MC44001 is designed to be part of a closed-loop system with the MCU; these flags are the feedback mechanism which allow the MCU to interact with the MC44001.

A brief description of each of the flags, its significance and possible uses are given below.

Table 4. Flags Returned

Clock #	Flag (Bit High)
10	Horizontal Flyback Present
11	Horizontal Drive Enabled
12	Horizontal Out Of Lock
13	Excess Average Beam Current
14	Less Than 576 Lines
15	Vertical Countdown Engaged
16	Overload Average Beam Current
17	Reserved
18	(Acknowledge)
19	Grid 2 Voltage Up Request
20	Grid 2 Voltage Down Request
21	OK
22	Fault
23	ACC Active
24	PAL Identified
25	SECAM Identified
26	Excess Peak Beam Current
27	(Acknowledge)

Horizontal Flyback Present – A sense of the horizontal flyback is taken via a current limiting series resistor from one of the flyback transformer secondaries to Pin 13. This is used for the H-phase shift control, but the presence of the pulse is also flagged to the MCU. Should the flag be missing after the chassis has been started up then the MCU would have to shut down the set immediately.

Horizontal Drive Enabled – Indicates that the horizontal drive pulse output at Pin 15 has been enabled. This occurs after the stored values in the nonvolatile memory have been transferred to the MC44001 memory.

Horizontal Out of Lock – This flag is high when no valid signal is being received by the MC44001. Possible action in this case would be to change the phase detector gain and time constant bits to ensure rapid capture and locking to a new signal.

Excess Average Beam Current – Is one of two conditions whose threshold levels are determined by an external

component network connected to beam current sensing Pin 9. This condition indicates an excess beam current as compared to the manufacturer's set maximum level during normal usage. A typical response to this warning indicator would be for the MCU to reduce the brightness and/or contrast.

Less Than 576 Lines – Output from the line counter in the vertical timebase. If there is a count of less than 576 this is indicative of a 525 line system being received. If the flag is low then a 625 line system is being received. This information can be used as a part of an automatic system selection software.

Vertical Countdown Engaged – The vertical timebase is based on a countdown system. The timebase starts in Injection Lock mode and when vertical retrace is initiated a 4-bit counter is set to zero. A coincidence detector looks for counts of 625 lines. In Auto mode each coincidence causes the counter to count up. When eight consecutive coincidences are detected the countdown is engaged. The MSB of the counter is used to set this flag to the processor.

Overload Average Beam Current – This is the second threshold level which is set by the external component network on Pin 9. The flag warns of an overload in anode current which could damage the CRT if allowed to continue. Appropriate action in this case is therefore to shut down the set.

Grid 2 Voltage Up/Down Requests – These flags indicate when the RGB output loops are about to go out of the control range necessary for correct gray scale tracking.

OK and Fault – These two flags are included as a check on the communication line between the MCU and MC44001. The OK flag is permanently wired high and Fault is permanently wired low. The MCU can use these flags to verify that the data received is valid.

ACC Active – This flag is high when there is a sufficient level of burst present in PAL and NTSC modes during the video back porch period. The flag goes low when the level of burst falls below a set threshold or if the signal becomes too noisy. The flag is used to implement a software color killer in PAL and NTSC and is also available for system identification purposes. Since in SECAM there is line carrier present during the gating period, it is quite likely that the ACC will be on, or will flicker on and off in this mode.

* **PAL Identified** – Recognizes the line-by-line swinging phase characteristic of the PAL burst. When this flag is on together with the ACC flag, this is positive identification for a PAL signal.

* **SECAM Identified** – Senses the changing line-by-line reference frequencies (Fo1 and Fo2) present during the back porch period of the SECAM signal. This flag alone provides identification that SECAM is being received.

* These two flags are set in opposition to one another such that they can never both be on at the same time. This has been done to try to prevent misidentification from occurring. Often it is very difficult to distinguish between PAL and SECAM especially when broadcast material has been transcoded, sometimes badly, leaving e.g. large amounts of SECAM carrier in a transcoded PAL signal (also often with noise). With this method the strongest influence will win out making a misidentification much less likely.

MC44001

Excess Peak Beam Current – A voltage threshold is set on the beam current feedback on Pin 20, which is also used for the RGB output loops for current sampling. When the threshold is reached the flag is set, indicating too high a peak beam current which may be in only a part of the screen. The response of the MCU might be to reduce the contrast of the

picture. This flag together with the excess average beam flag already described perform the function of beam limiting. The exact way in which this is handled is left to the discretion of the user who will have their own requirements, which may be incorporated by the way in which the software is written.

READING AND WRITING TO THE MC44001

Flag reading may be done at any time during a field. However, writing to the MC44001 must be restricted to certain times. If writing of new data is done during the middle of a field, a disturbance will be seen on the screen, particularly for the four user controls. While writing during the vertical interval may appear to be the obvious solution for this, there is a limited time available due to the contrast control function which is carried out with RGB sampling

loops during this interval. Writing during this particular time can cause the sampling loops to become unstable.

The time available for writing new data is approximately 1.2 ms from the beginning of the field flyback pulse to the beginning of the RGB sampling. It is only the third byte (data byte) which is restricted to this time interval. The first two bytes may be sent previous to this, or also during this time.

Table 5. System Identification

Flags From Chroma 4				Crystal (MHz)	Standard Selected By MCU
<576 Lines	ACC On	PAL	SECAM		
0	0	0	0	17.7	Kill
0	0	0	1	17.7	SECAM
0	0	1	0	17.7	Kill
0	0	1	1	17.7	I ² C Bus Error
0	1	0	0	17.7	Kill
0	1	0	1	17.7	SECAM
0	1	1	0	17.7	PAL
0	1	1	1	17.7	I ² C Bus Error
1	0	0	0	14.3	Kill
1	0	0	1	14.3	Kill
1	0	1	0	14.3	Kill
1	0	1	1	14.3	I ² C Bus Error
1	1	0	0	14.3	NTSC
1	1	0	1	14.3	NTSC
1	1	1	0	14.3	NTSC
1	1	1	1	14.3	I ² C Bus Error

- NOTES:** 1. The table above can be used for color standard selection between the normal PAL (I, BG), SECAM (L, BG) and NTSC (3.58 MHz – M) Standards. To detect the hybrid VCR standard (525 lines with 4.4 MHz chrominance) would entail switching back to the 17.7 MHz crystal in the event of there being no flags present with the 14.3 MHz crystal.
2. Chroma 4 could also be used for the PAL M & N Standards that are used in some parts of South America, but because the subcarrier frequencies used differ by some kHz from the normal, crystals with a different center frequency would be required.

Table 6. Mode Definitions

Mode Selected	Control Bits				
	XS*	NORM*	SSA	SSB	SSC
Kill (17.7 MHz)	0	0	1	1	0
Kill (14.3 MHz)	1	1	1	1	0
PAL (I, BG)	0	0	0	1	0
SECAM	0	0	0	0	0
NTSC (M)	1	1	1	0	0

*Control bits XS and NORM are always changed together.

**MOTOROLA
SEMICONDUCTOR
TECHNICAL DATA**

Advance Information
**Bus Controlled Multistandard
Video Processor**

The Motorola MC44011, a member of the MC44000 Chroma 4 family, is designed to provide RGB or YUV outputs from a variety of inputs. The inputs can be composite video (two inputs), S-VHS, RGB, and color difference (R-Y, B-Y). The composite video can be PAL and/or NTSC as the MC44011 is capable of decoding both systems. Additionally, R-Y and B-Y outputs and inputs are provided for use with a delay line where needed. Sync separators are provided at all video inputs.

In addition, the MC44011 provides a sampling clock output for use by a subsequent triple A/D converter system which digitizes the RGB/YUV outputs. The sampling clock (6.0 to 40 MHz) is phase-locked to the horizontal frequency.

Additional outputs include composite sync, vertical sync, field identification, luma, burst gate, and horizontal frequency.

Control of the MC44011, and reading of status flags, is via an I²C bus.

- Accepts NTSC and PAL Composite Video, S-VHS, RGB, and R-Y, B-Y
- Includes Luma and Chroma Filters, Luma Delay Lines, and Sound Traps
- Digitally Controlled via I²C Bus
- R-Y, B-Y Inputs for Alternate Signal Source
- Line-Locked Sampling Clock for A/D Converters
- Burst Gate, Composite Sync, Vertical Sync and Field Identification Outputs
- RGB/YUV Outputs can provide 3.0 V_{p-p} for A/D Inputs
- Overlay Capability
- Single Power Supply: + 5.0 V, ± 5%, 550 mW (Typical)
- 44 Pin PLCC Package

MC44011

**BUS CONTROLLED
MULTISTANDARD
VIDEO PROCESSOR**

SILICON MONOLITHIC
INTEGRATED CIRCUIT

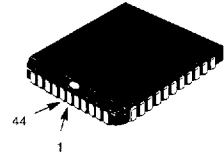

FN SUFFIX
PLASTIC PACKAGE
CASE 777
(PLCC)

ORDERING INFORMATION

Device	Temperature Range	Package
MC44011FN	0° to + 70°C	PLCC-44

9

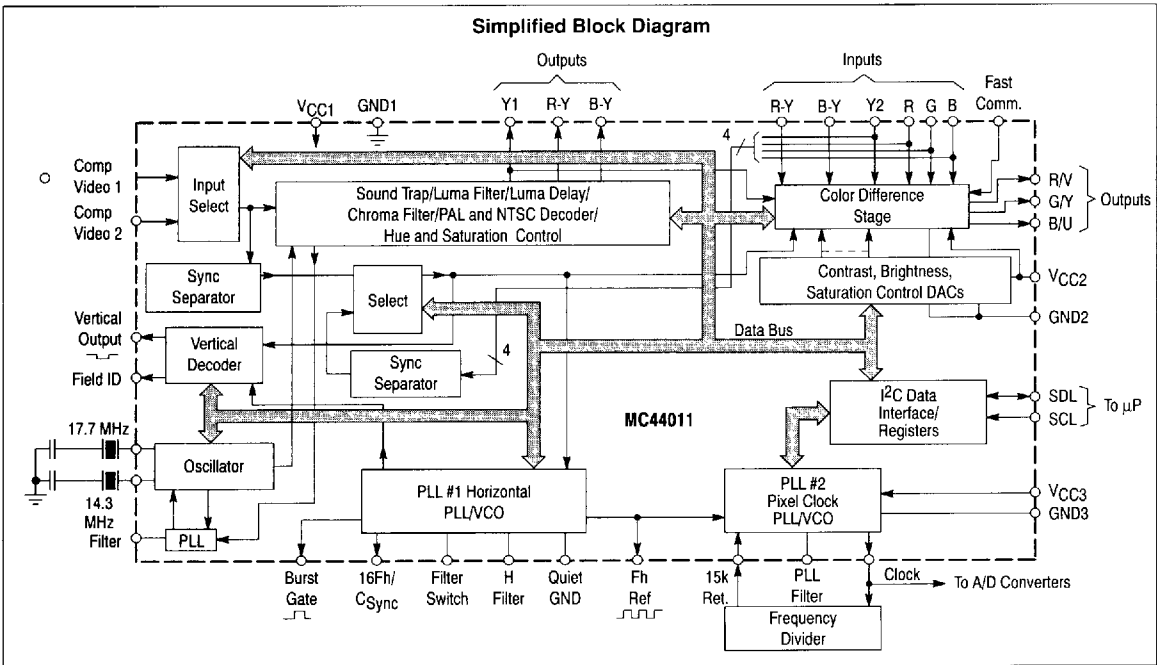

MC44011

Figure 1. MC44011 Block Diagram

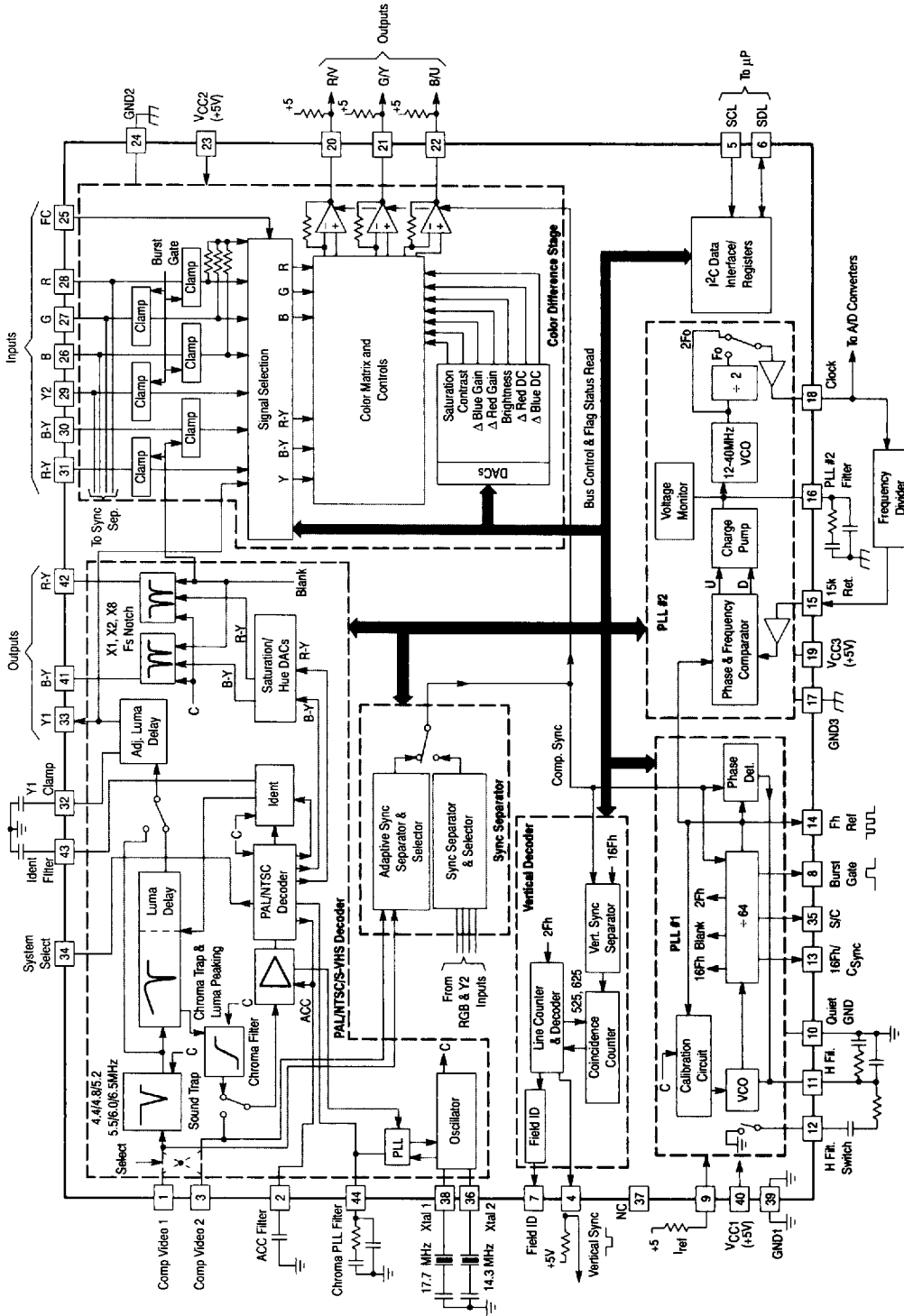

MC44011

ELECTRICAL CHARACTERISTICS (The tested electrical characteristics are based on the conditions shown in Table 1 and 2. Composite Video input signal = 1.0 V_{p-p}, composed of: 0.7 V_{p-p} Black-to-White; 0.3 V_{p-p} Sync-to-Black; 0.3 V_{p-p} Color Burst. VCC1 = VCC2 = VCC3 = +5.0 V, I_{ref} = 32 μA (Pin 9), unless otherwise noted.)

Table 1. Control Bit Test Settings

Control Bit	Name	Value	Function
\$77-7	S-VHS-Y	0	Composite Video input selected.
\$77-6	S-VHS-C	0	Composite Video input selected.
\$77-5	FSI	0	50 Hz Field Rate selected.
\$77-4	L2 GATE	0	PLL #2 Gating enabled.
\$77-3	BLCP	0	Clamp Pulse Gating enabled.
\$77-2	L1 GATE	0	Vertical Gating enabled.
\$77-1, 0	CB1, CA1	1,1	Vertical section Auto-Countdown mode
\$78-7	36/68 μs	0	Time from beginning of Line 4 to Vertical Sync is 36 μs.
\$78-6	CalKill	0	Horizontal Calibration Loop enabled.
\$79-7, 6	HI, VI	1,1	Normal
\$7A-7	Xtal	→	0 = 17.7 MHz crystal selected, 1 = 14.3 MHz crystal selected.
\$7A-6	SSD	0	Normal
\$7B-7, 6	T1, T2	1,1	Sound Trap Notch filter set to 5.5 MHz (with 17.7 MHz crystal).
\$7C-7	SSC	0	Permits PAL and NTSC selection.
\$7C-6, \$7D-6	SSA, SSB	→	0, 1 = PAL decoding, 1, 0 = NTSC decoding
\$7D-7, \$7E-7, 6	P1, P3, P2	1, 1, 1	Sets Luma Peaking at 0 dB.
\$7F-7, 6, \$80-6	D3, D1, D2	0, 0, 0	Set Luma Delay to minimum
\$80-7	RGB EN	0	Fast Commutate input can enable RGB inputs.
\$81-7	Y2 EN	0	Y2 input (Pin 29) deselected
\$81-6	Y1 EN	1	Y1 luma path from PAL/NTSC decoder selected.
\$82-7	YUV EN	0	RGB output mode selected
\$82-6	YX EN	0	Disable luma matrix from RGB inputs.
\$83-7	L2 Gain	0	Set PLL #2 Phase/Frequency detector gain high.
\$83-6	L1 Gain	1	Set PLL #1 Phase Detector gain high.
\$84-7	H Switch	0	Set Horizontal Phase Detector filter switch open.
\$84-6	525/625	→	0 = 625 lines (PAL), 1 = 525 lines (NTSC)
\$85-7	F _{osc} ÷ 2	0	Select direct VCO output from PLL #2.
\$85-6	C _{Sync}	0	16 Fh output selected at Pin 13.
\$86-7	V _{in} Sync	1	Composite Video inputs (Pin 1 or 3) Sync Source selected.
\$86-6	H EN	0	Enabled Horizontal Timebase.
\$87-7	Y2 Sync	0	Y2 sync source not selected.
\$88-7	V2/V1	1	Select Video 1 input (Pin 1).
\$88-6	RGB Sync	0	RGB inputs Sync Source not selected.

Table 2. DAC Test Settings

DAC	Value	Function	DAC	Value	Function
\$78	32	R-Y/B-Y Gain	\$82	32	Red Contrast Trim
\$79	32	Sub Carrier Phase	\$83	32	Blue Brightness Trim
\$7D	00	Blue Output DC Bias	\$84	32	Main Brightness
\$7E	00	Red Output DC Bias	\$85	32	Red Brightness Trim
\$7F	63	Pixel Clock VCO Gain	\$86	32	Saturation (Color Diff.)
\$80	32	Blue Contrast Trim	\$87	16	Saturation (Decoder)
\$81	32	Main Contrast	\$88	32	Hue

Currents out of a pin are designated -, and those into a pin are designated +.

MAXIMUM RATINGS

Parameter	Symbol	Value	Unit
Power Supply Voltage	V _{CC1} V _{CC2} V _{CC3}	-0.5 to +6.0 -0.5 to +6.0 -0.5 to +6.0	V _{dc}
Power Supply Difference (Between any two V _{CC} pins)		±0.5	V _{dc}
Input Voltage: Video 1, 2, SCL, SDL 15 kHz Return R-Y, B-Y, Y2, RGB, FC	V _{in}	-0.5, V _{CC1} + 0.5 -0.5, V _{CC3} + 0.5 -0.5, V _{CC2} + 0.5	V _{dc}
Junction Temperature (Storage and Operating)	T _J	-65 to +150	°C

Devices should not be operated at these limits. The "Recommended Operating Conditions" table provides for actual device operation.

RECOMMENDED OPERATING CONDITIONS

Parameter	Symbol	Min	Typ	Max	Unit
Power Supply Voltage	V _{CC1, 2, 3}	+4.75	+5.0	+5.25	V _{dc}
Power Supply Difference (Between any two V _{CC} pins)	ΔV _{CC}	-0.5	0	+0.5	V _{dc}
Input Voltage: Video 1, 2 (Sync-White) Chroma (S-VHS Mode) Y2 RGB R-Y, B-Y (Pins 30, 31) 15 kHz Return SCL, SDL FC Burst Signal Sync Amplitude	V _{in}	0.7 — 0.7 0.5 0 0 0 0 30 60	1.0 — 1.0 0.7 — — — 280 300	1.4 1.2 1.4 1.0 1.8 V _{CC3} V _{CC1} V _{CC2} 560 V _{CC1}	V _{p-p} V _{dc} mV _{p-p} mV _{p-p}
Output Load Impedance to Ground: RGB (Pull-up = 390 Ω) B-Y, R-Y Y1	RL _{RGB} RL _{CD} RL _{Y1}	1.0 10 1.0	— — —	∞ ∞ ∞	kΩ
Pull-up Resistance at Vertical Sync (Pin 4)	R _{VS}	1.0	10	—	kΩ
Source Impedance: Video 1, 2 Pins 26 to 31		0 0	— —	1.0 1.0	kΩ
Pixel Clock Frequency (Pin 18, see PLL #2 Electrical Characteristic)	f _{px}	—	2.0 to 45	—	MHz
15 kHz Return Pulse Width (Low Time)	PW _{15k}	0.2	—	45	μs
I ² C Clock Frequency	f _{I²C}	—	—	100	kHz
Reference Current (Pin 9)	I _{ref}	—	32	—	μA
Operating Ambient Temperature	T _A	0	—	70	°C

All limits are not necessarily functional concurrently.

ELECTRICAL CHARACTERISTICS (T_A = +25°C, V_{CC1} = V_{CC2} = V_{CC3} = 5.0 V, unless otherwise noted.)

Parameter	Min	Typ	Max	Unit
POWER SUPPLIES				
Power Supply Current (V _{CC} = +5.0 V)				mA
Pin 40	75	95	115	
Pin 23	6.0	9.0	12	
Pin 19	3.5	6.0	8.0	
Total	85	110	135	

MC44011

ELECTRICAL CHARACTERISTICS (T_A = +25°C, V_{CC1} = V_{CC2} = V_{CC3} = 5.0 V, unless otherwise noted.)

Parameter	Min	Typ	Max	Unit
PAL/NTSC/S-VHS DECODER				
Video 1, 2 Inputs				
Crosstalk Rejection, f = 1.0 MHz (Measured at Y1 output, Luma Peaking = 0 dB, \$77-7 = 1)	20	40	—	dB
DC Level: @ Selected Input	—	2.8	—	Vdc
@ Unselected Input	—	0.7	—	
Clamp Current	-30	-20	-10	μA
Sound Trap Rejection (See Figures 14 to 23)				
With 17.7 MHz Crystal: @ 6.5 MHz (T1, T2 = 00)	15	30	—	dB
@ 6.0 MHz (T1, T2 = 10)	15	30	—	
@ 5.5 MHz (T1, T2 = 11)	10	43	—	
@ 5.74 MHz (T1, T2 = 01)	15	26	—	
With 14.3 MHz Crystal: @ 4.44 MHz (T1, T2 = 11)	—	35	—	
R-Y, B-Y Outputs (Pins 41, 42)				
Output Amplitude (with 100% Saturated Color Bars)				
Saturation (DAC 87) = 00	—	<1.0	—	mVp-p
Saturation (DAC 87) = 16	—	1.6	—	Vp-p
Saturation (DAC 87) = 63	1.5	1.8	—	
DC Level During Blanking				
Hue Control - Minimum Phase (DAC 88 = 00)	-30	—	—	Deg
- Maximum Phase (DAC 88 = 63)	+30	—	—	
Nominal Saturation (with respect to Y1 Output, Note 1)				
B-Y/R-Y Ratio: Balance (DAC 78) = 63	1.35	1.69	2.06	V/V
Balance (DAC 78) = 32	0.98	1.27	1.58	
Balance (DAC 78) = 00	0.60	0.77	0.96	
Output Amplitude Variation as Burst is varied from 80 mVp-p to 600 mVp-p				
Color Kill Attenuation (\$7C-7, 6 and \$7D-6 = 011)	—	40	—	dB
Crosstalk with respect to Y1 Output (@ 1.0 MHz)	-27	-20	—	
Chroma Subcarrier Residual (Measured at Y1 Output, with 17.7 MHz Crystal)				
f = Subcarrier	—	25	60	mVp-p
2nd Harmonic Residual	—	4.0	12	
4th Harmonic Residual	—	12	30	
(Measured at R-Y, B-Y Outputs, with 17.7 or 14.3 MHz Crystal)				
f = Subcarrier	—	5.0	20	
2nd Harmonic Residual	—	5.0	20	
4th Harmonic Residual	—	15	50	
Y1 Luma Output (Pin 33)				
Clamp Level	0.4	1.1	1.8	Vdc
Output Impedance	—	300	—	Ω
Composite Video Mode (\$77-6, 7 = 00)				
Output Level versus Input Level				
Delay = 000, Peaking = 111, f = 100 kHz	1.0	1.1	1.2	V/V
Delay = Min-to-Max, Peaking = Min-to-Max	—	1.1	—	
-3 dB Bandwidth (17.7 MHz Crystal, PAL Decoding selected, Sound trap at 6.5 MHz, Peaking off)				
Peaking Range (\$7D-7, \$7E-6/7 = 000 to 111, @ 3.0 MHz, with 17.7 MHz Crystal, Sound trap at 6.5 MHz)	5	8	10	dB
Overshoot with Minimum Peaking				
Differential Non-linearity (Measured with Staircase)	—	0	—	%
Delay (Pin 1 or 3 to 33)	—	2.0	—	%
With 14.3 MHz Crystal: Minimum				
Maximum	—	690	—	ns
Maximum	—	1040	—	
With 17.7 MHz Crystal: Minimum				
Maximum	—	594	—	
Maximum	—	876	—	

NOTE: 1. This spec indicates a correct output amplitude at Pins 41 and 42, with respect to Y1 output. For standard color bar inputs, the output amplitude is between 1.5 and 1.7 Vp-p, with the settings in Tables 1 and 2.

ELECTRICAL CHARACTERISTICS ($T_A = +25^\circ\text{C}$, $V_{CC1} = V_{CC2} = V_{CC3} = 5.0\text{ V}$, unless otherwise noted.)

Parameter	Min	Typ	Max	Unit
PAL/NTSC/S-VHS DECODER				
S-VHS Mode (\$77-6, 7 = 11)				
Output Level versus Input Level (Delay = Min-to-Max)	1.0	1.1	1.2	V/V
- 3 dB Bandwidth (17.7 MHz crystal, PAL Decoding selected, Sound trap at 6.5 MHz)	—	4.5	—	MHz
Y/C Crosstalk Rejection	20	40	—	dB
Delay (Luma input to Pin 33)				
14.3 MHz Crystal: Minimum	—	395	—	ns
Maximum	—	745	—	
17.7 MHz Crystal: Minimum	—	350	—	
Maximum	—	632	—	
Crystal Oscillator				
PLL Pull-in range with respect to Subcarrier Frequency (Burst Level $\geq 30\text{ mVp-p}$): with 17.7 MHz Crystal	—	± 350	—	Hz
with 14.3 MHz Crystal	—	± 300	—	
$4f_{sc}$ Filter (Pin 44) DC Voltage				Vdc
@ 14.3 MHz	—	2.4	—	
@ 17.7 MHz	—	3.5	—	
No Burst present	—	1.3	—	
DC Voltages				
System Select (Pin 34)				Vdc
NTSC Mode (SSA = 1, SSB = 0, SSC = 0, SSD = 0)	1.5	1.75	2.0	
PAL Mode (SSA = 0, SSB = 1, SSC = 0, SSD = 0)	0	0.075	0.4	
Color Kill Mode (SSA = 1, SSB = 1, SSC = 0, SSD = 0)	—	0.075	—	
External Mode (SSA = X, SSB = X, SSC = 1, SSD = 0)	3.7	4.0	4.3	
Ident Filter (Pin 43)				
NTSC Mode	—	1.6	—	
PAL Mode	1.2	1.5	1.8	
No Burst present	—	0.2	—	
ACC Filter (Pin 2)				
No Burst present	—	0.25	—	
Threshold for ACC Flag on	0.8	1.2	1.6	
Burst = 50 mVp-p	—	1.4	—	
Burst = 280 mVp-p	—	1.7	—	
System Select Output Impedance	—	40	100	k Ω
COLOR DIFFERENCE SECTION				
RGB/YUV Outputs				
Output Swing, Black-to-White (DAC \$81 = 63)	2.0	3.0	—	Vp-p
THD (RGB Inputs to RGB Outputs @ 1.0 MHz, 0.7 Vp-p)	—	0.5	2.0	%
- 3 dB Bandwidth	—	6.0	—	MHz
Clamp Level				Vdc
RGB Outputs (\$7D, 7E = 00)	—	1.4	—	
UV Outputs (\$7D, 7E = 32)	—	2.3	—	
Red, Blue Clamp Level Change (DACs \$7D, 7E varied from 00 to 63)	0.85	1.8	2.4	
Crosstalk Rejection				
Among RGB Outputs @ 1.0 MHz	20	40	—	dB
Y1 to Y2	20	40	—	
From RGB Outputs to Y1 or Y2	20	40	—	
Input Black Clamp Voltage at Y2, B-Y, R-Y, and RGB	2.4	3.0	3.6	Vdc
Fast Commutate Input (Pin 25)				
Switching Threshold Voltage	—	0.5	—	Vdc
Input Current @ $V_{in} = 0\text{ V}$	—	-7.5	—	μA
Input Current @ $V_{in} = +5.0\text{ V}$	—	0	—	
Timing: Input Low-to-High (RGB Enable)	—	50	—	ns
Input High-to-Low (RGB Disable)	—	90	—	

MC44011

ELECTRICAL CHARACTERISTICS ($T_A = +25^\circ\text{C}$, $V_{CC1} = V_{CC2} = V_{CC3} = 5.0\text{ V}$, unless otherwise noted.)

Parameter	Min	Typ	Max	Unit
COLOR DIFFERENCE SECTION				
Contrast (Gain)				V/V
Y1 to RGB (DAC \$81 = 32, DAC \$86 = 00)	1.9	2.4	3.0	
Y2 to RGB (DAC \$81 = 32, DAC \$86 = 00)	1.8	2.3	2.8	
Green In (Pin 27) to Green Out (Pin 21) with YX Enabled (\$82-6 = 1, DAC \$81 and DAC \$86 = 32)	1.8	2.3	2.4	
Red-to-Green and Blue-to-Green Gain Ratio	0.8	1.0	1.2	
RGB Input to RGB Output with YX Not Enabled (\$82-6 = 0, DAC \$81 and DAC \$86 = 32)	2.0	2.6	3.2	
Ratio (DAC \$81 = 00 versus 32)	—	0.2	0.4	
Ratio (DAC \$81 = 63 versus 32)	1.5	2.0	2.5	
Red and Blue Trim Control (DACs \$80, 82 varied from 00 to 63)	± 5	± 30	± 60	%
Saturation (Average of R, G, B saturation levels with respect to Luma)				
Inputs at Pins 29 to 31 (DAC \$86 = 32)	50	90	130	%
Ratio (DAC \$86 = 00 versus 32)	—	—	5	
Ratio (DAC \$86 = 63 versus 32)	150	170	190	
Inputs at Pins 26 to 28 (DAC \$86 = 32, \$82-6 = 1)	70	125	180	
Brightness				Vdc
Black Level Range (Brightness = 00 to 63 with respect to Brightness setting of 32)	± 0.3	± 0.5	± 0.7	
Red and Blue Trim Control (DACs \$83, 85 varied from 00 to 63)	± 0.05	± 0.3	± 0.6	
Color Coefficients				
G-Y Matrix Coefficient versus B-Y	-0.21	-0.19	-0.17	
G-Y Matrix Coefficient versus R-Y	-0.56	-0.51	-0.46	
YX Matrix (Inputs at Pins 26 to 28, \$82-6 = 1):				
Y versus R	0.28	0.30	0.32	
Y versus G	0.57	0.59	0.61	
Y versus B	0.09	0.11	0.13	

HORIZONTAL TIME BASE SECTION (PLL #1)

Free-Running Period (Calibration mode in effect, Bit \$86-6 = 1)				
17.7 MHz Crystal selected (\$84-6 = 0)	62.5	64.0	65.5	μs
14.3 MHz Crystal selected (\$84-6 = 1)	62.5	63.5	65.5	
VCO minimum period (Pin 11 Voltage at 1.2 V)	56	59.5	62	μs
VCO maximum period (Pin 11 Voltage at 2.8 V)	66	69.5	72	
VCO Control Gain factor	5.0	8.5	12	$\mu\text{s/V}$
Phase Detector Current				
High Gain (\$83-6 = 1)	15	50	85	μA
Low Gain-to-High Gain Current Ratio	0.32	0.38	0.44	$\mu\text{A}/\mu\text{A}$
Noise Gate Width (\$77-2 = 0, Low Gain, see Figure 26)	—	16	—	μs
Horizontal Filter Switch (Pin 12)				
Saturation Voltage ($I_{12} = 20\ \mu\text{A}$)	—	10	100	mV
Dynamic Impedance (\$84-7 = 1)	—	< 5.0	—	k Ω
Parallel Resistance (\$84-7 = 0)	0.6	1.0	—	M Ω
Pins 8, 13, 14 Output Level				Vdc
High ($I_O = -40\ \mu\text{A}$)	2.4	4.5	—	
Low ($I_O = +800\ \mu\text{A}$)	—	0.1	0.8	
Burst Gate (Pin 8) Timing (See Figures 25, 27)				μs
Rising edge from Sync leading edge (Pins 1, 3)	4.4	5.6	6.8	
Rising edge from Sync center (Pins 26 to 29)	—	2.5	—	
Pulse Width	3.0	3.5	4.0	
16 Fh Output (Pin 13) Timing (Bit \$85-6 = 0) (See Figures 25, 27)				
Rising edge from Fh rising edge	—	1.3	—	μs
Duty Cycle	—	50	—	%
Composite Sync Output (Pin 13) Timing (Bit \$85-6 = 1)				μs
Input Sync center to Output Sync center (Pins 1, 3)	—	0.95	—	
Input Sync center to Output Sync center (Pins 26 to 29)	—	0.4	—	

MC44011

ELECTRICAL CHARACTERISTICS ($T_A = +25^\circ\text{C}$, $V_{CC1} = V_{CC2} = V_{CC3} = 5.0\text{ V}$, unless otherwise noted.)

Parameter	Min	Typ	Max	Unit
HORIZONTAL TIME BASE SECTION (PLL #1)				
Fh Reference (Pin 14) Timing (See Figures 25, 27)				
Rising edge from Sync center (Pins 1, 3)	—	1.3	—	μs
Rising edge from Sync center (Pins 26 to 29)	—	650	—	ns
Duty cycle	—	50	—	%
Sandcastle Output (Pin 35, see Figures 25, 27)				Vdc
Output Voltage – Level 1	3.7	4.0	4.3	
Output Voltage – Level 2	2.8	3.0	3.2	
Output Voltage – Level 3	—	1.55	—	
Output Voltage – Level 4	—	0.07	—	
Rising edge from Sync center (Pins 1, 3)	—	-2.6	—	μs
Rising edge from Sync center (Pins 26 to 29)	—	-3.3	—	
High Time	—	6.0	—	
Level 2 Time	—	5.0	—	
Reference Voltage @ Pin 9 ($I_{\text{ref}} = 32\ \mu\text{A}$)	1.0	1.2	1.4	Vdc

PHASE-LOCKED PIXEL CLOCK SECTION (PLL #2)

VCO Frequency @ Pin 18				MHz
Minimum (Pin 16 = 1.6 V, \$85-7 = 1)	—	2.0	4.0	
Maximum (Pin 16 = 4.0 V, \$85-7 = 0)	30	45	60	
VCO Up (Flag 19) Threshold Voltage @ Pin 16	1.5	1.7	1.9	Vdc
VCO Down (Flag 20) Threshold Voltage @ Pin 16	3.1	3.3	3.5	
VCO Control Voltage Range @ Pin 16	1.2	—	3.8	Vdc
VCO Control Gain factor (\$7FDAC = 00, \$85-7 = 0)	4.0	8.0	12	MHz/V
Charge Pump Current (Pin 16)	25	50	75	μA
High Gain (\$83-7 = 0)				
Current Ratio	0.3	0.4	0.5	$\mu\text{A}/\mu\text{A}$
Low Gain-to-High Gain				
Pixel Clock Output (Pin 18) (Load = 3 FAST TTL loads + 10 pF)				Vdc
Output Voltage – High	—	3.9	—	
Output Voltage – Low	—	0.15	—	
Rise Time @ 50 MHz	—	7.0	—	ns
Rise Time @ 9.0 MHz	—	17	—	
Fall Time @ 50 MHz	—	5.0	—	
Fall Time @ 9.0 MHz	—	8.0	—	
15 kHz Return (Pin 15)				Vdc
Input Threshold Voltage	—	1.5	—	
Falling edge from Fh rising edge	—	60	—	ns
Minimum Input Low Time	200	—	—	

VERTICAL DECODER

Vertical Frequency Range	43.3	—	122	Hz
Vertical Sync Output				
Saturation Voltage ($I_O = 800\ \mu\text{A}$)	—	0.1	0.8	V
Leakage Current @ 5.0 V (Output high)	—	—	40	μA
Timing from Sync polarity reversal to Pin 4 falling edge (See Figures 33, 34)				μs
(\$78-7 = 0)	32	36	40	
(\$78-7 = 1)	62	68	74	
Vertical Sync Pulse Width (Pin 4, NTSC or PAL)	490	500	510	μs
Field Ident (Pin 7)				Vdc
Output Voltage – High ($I_O = -40\ \mu\text{A}$)	2.4	4.5	—	
Output Voltage – Low ($I_O = +800\ \mu\text{A}$)	—	0.1	0.8	
Timing	—	Fig. 33, 34	—	

HORIZONTAL SYNC SEPARATOR

Sync Slicing Levels (Pins 1, 3)	—	120	—	mV
From Black Level (Pins 26 to 29)	—	150	—	

MC44011

PIN FUNCTION DESCRIPTION

Pin No.	Representative Circuitry	Description
1, 3		Video Input 1 & 2 – Video 1 (Pin 1) and Video 2 (Pin 3) are composite video inputs. Either can be NTSC or PAL. Input impedance is high, termination must be external. Also used for the luma and chroma components of an S-VHS signal. Selection of these inputs is done by software. External components protect against ESD and noise.
2		ACC Filter – A 0.1 μF capacitor at this pin filters the feedback loop of the chroma automatic gain control amplifier. Input chroma burst amplitude can be between 30 and 600 $\text{mV}_{\text{p-p}}$.
4		Vertical Sync Output – An open collector output requiring an external pull-up. Output is an active low pulse, 500 μs wide, occurring each field. Timing of this pulse depends on Bit \$78-7.
5		SCL – Clock for the I^2C bus interface. See Appendix C for specifications. Maximum frequency is 100 kHz.
6		SDL – Bidirectional data line for the I^2C bus interface. As an output, it is an open collector. (Write Address \$8A, Read Address \$8B)
7		Field ID – TTL level output indicating Field 1 or Field 2. Polarity depends on state of Bit \$78-7 (Vert. Sync Delay). See Table 11 and Figure 33 and 34.
8	(Same as Pin 7)	Burst Gate – TTL level output used for external clamps, as well as internally. Pulse is active high, $\approx 3.5 \mu\text{s}$ wide, with the rising edge $\approx 3.0 \mu\text{s}$ after center of selected incoming sync pulse.
9		Reference Current Input – Current supplied to this pin, typically 32 μA from + 5.0 V through a 110 $\text{k}\Omega$ resistor, is the reference current for the calibration circuit. Noise filtering should be done at the pin. Voltage at this pin is typically 1.2 V.
10	(See power distribution diagram at the end of this section.)	Quiet Ground – Ground for the horizontal PLL filter (PLL #1) at Pin 11.

MC44011

PIN FUNCTION DESCRIPTION

Pin No.	Representative Circuitry	Description
11		H Filter – Components at this pin filter the output of the phase detector of PLL #1. This PLL becomes phase-locked to the selected incoming horizontal sync. External component values are valid for NTSC and PAL systems.
12		H Filter Switch – An internal switch-to-ground which permits altering the filtering action of the components at Pin 11.
13	(Same as Pin 7)	16 Fh/CSync – A TTL level output from PLL #1. This pin provides either a square wave equal to $F_h \times 16$ (≈ 250 kHz), or composite sync, depending on the setting of Bit \$85-6.
14	(Same as Pin 7)	Fh Reference – A TTL square wave output which is phase-locked to the selected incoming horizontal sync. The rising edge occurs $\approx 1.3 \mu s$ after sync center.
15		15 kHz Return – This TTL input receives the output of an external frequency divider which is part of PLL #2 (Pixel Clock PLL). This signal will be phase and frequency-locked to the Fh signal at Pin 14. If PLL #2 is not used, this pin should be connected to a +5.0 V supply.
16		PLL #2 Filter – Components at this pin filter the output of the phase detector of PLL 2. This PLL becomes phase-locked to the Fh signal at Pin 14. Recommended values for filter components are shown. External components should be connected to ground at Pin 17. If PLL #2 is not used, this pin should be grounded.
17	(See power distribution diagram at the end of this section.)	GND 3 – Ground for the high frequency PLL #2. Signals at Pins 15 to 19 should be referenced to this ground.
18		Pixel Clock Output – Sampling clock output (TTL) for external A/D converters, and for the external frequency divider. Frequency range at this pin is 6.0 to 40 MHz.
19	(See power distribution diagram at the end of this section.)	VCC3 – A +5.0 V supply ($\pm 5\%$), for the high frequency PLL #2. Decoupling must be provided from this pin to Pin 17. Ripple on this pin will affect pixel clock jitter.

MC44011

PIN FUNCTION DESCRIPTION

Pin No.	Representative Circuitry	Description
20		R/V Output – Red (in RGB mode), or R-Y (in YUV mode), output from the color difference stage. A pull-up (390 Ω) to +5.0 V is required. Blank level is $\approx +1.4$ Vdc. Maximum amplitude is = 3.0 Vp-p, black-to-white.
21	(Same as Pin 20)	G/Y Output – Green (in RGB mode), or Y (in YUV mode), output from the color difference stage (same as Pin 20).
22	(Same as Pin 20)	B/U Output – Blue (in RGB mode), or B-Y (in YUV mode), output from the color difference stage (same as Pin 20).
23	(See power distribution diagram at the end of this section.)	VCC2 – A +5.0 V supply ($\pm 5\%$), for the color difference stage. Decoupling must be provided from this pin to Pin 24.
24	(See power distribution diagram at the end of this section.)	GND 2 – Ground for the color difference stage. Signals at Pins 20 to 31 should be referenced to this pin.
25		FC – Fast Commutate switch. Taking this pin high (TTL level) connects the RGB inputs (Pins 26 to 28) to the RGB outputs (Pins 20 to 22), permitting an overlay function. The switch can be disabled in software (Bit \$80-7).
26, 27, 28		Blue (26), Green (27), Red (28) Inputs – Inputs to the color difference stage. Designed to accept standard analog video levels, these input pins have a clamp and sync separator. They are selected with Pin 25 or in software (Bit \$80-7).
29		Y2 Input – Luma #2/Composite sync input. This luma input to the color difference stage is used in conjunction with auxiliary color difference inputs, and/or as a sync input. Clamp and sync separator are provided.
30, 31		B-Y (30), R-Y (31) Inputs – Inputs to the color difference stage. Designed for standard color difference levels, these inputs can be capacitor coupled from the color difference outputs, from a delay line, or an auxiliary signal source. Input clamp is provided.
32		Y1 Clamp – A 0.47 μF capacitor at this pin provides clamping for the Luma #1 output.
33		Y1 Output – Luma #1 output. This output from the PAL/NTSC/S-VHS decoder is the luma component of the decoded composite video at Pin 1 or 3. It is internally directed to the color difference stage.
34		System Select – A multi-level DC output which indicates the color decoding system to which the PAL/NTSC detector is set by the software. This output is used by the MC44140 chroma delay line.

PIN FUNCTION DESCRIPTION

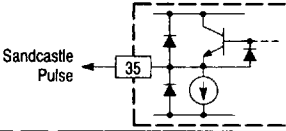
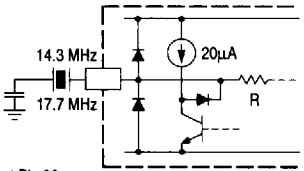
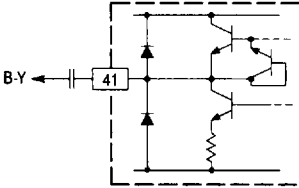
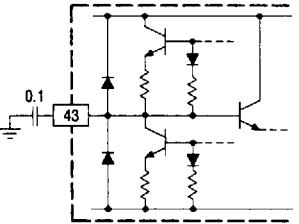
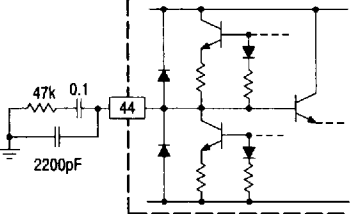
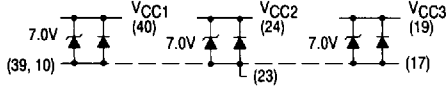
Pin No.	Representative Circuitry	Description
35		Sandcastle Pulse – A multi-level timing pulse output used by the MC44140 chroma delay line. This pulse encompasses the horizontal sync and burst time.
36, 38	 R = 400 Ω at Pin 38 R = 300 Ω at Pin 36	Xtal 2 (36), Xtal 1 (38) – Designed for connection of 4x subcarrier color crystals. Selection is done in software. The selected frequency is used by the PAL/NTSC detector; system identifier; all notches and traps; delay lines; and the horizontal calibration circuit. The crystal frequency should be: 14.3 MHz at Pin 36 for NTSC, 17.7 MHz at Pin 38 for PAL. (See Table 18 for crystal specs.)
37		No Connect – This pin is to be left open.
39	(See power distribution diagram at the end of this section.)	Ground 1 – Ground for all sections except PLL #2 and the color difference stage.
40	(See power distribution diagram at the end of this section.)	VCC1 – A + 5.0 V (± 5%), supply to all sections except PLL #2 and the color difference stage.
41		B-Y Output – Output from the PAL/NTSC decoder, it is typically capacitor-coupled to a delay line or to the B-Y input. This pin is clamped, and filtered at the color subcarrier frequency, 2x, and 8x that frequency.
42	(Same as Pin 41)	R-Y Output – Output from the PAL/NTSC decoder.
43		Ident Filter – A 0.1 µF capacitor filters the system identification circuit in the NTSC/PAL decoder.
44		Crystal PLL Filter – Components at this pin filter the PLL for the crystal chroma oscillator circuit.
10, 17, 19, 23, 24, 39, 40	 (Dashed lines indicate substrate connection.)	Power Distribution – The three VCC pins must be externally connected to + 5.0 V (± 5%) supply. The four grounds must be externally tied together, preferably to a ground plane.

MC44011

Luma Frequency Response (14.3 MHz) Crystal, (4.5 MHz) Sound Trap

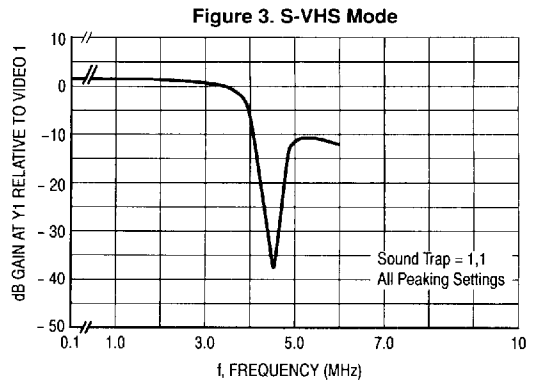
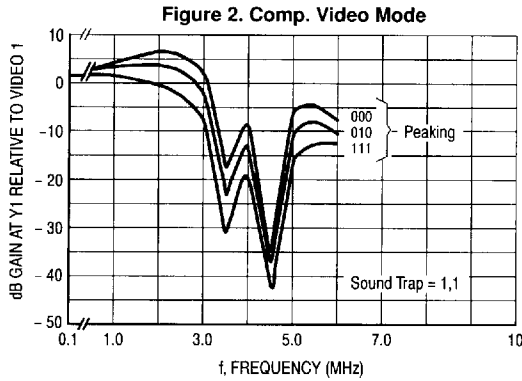

Luma Frequency Response (17.7 MHz) Crystal, (5.5 MHz) Sound Trap

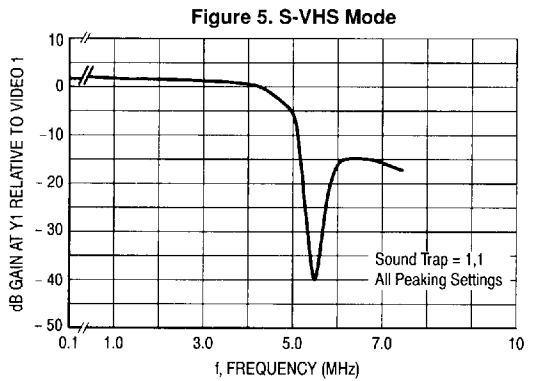
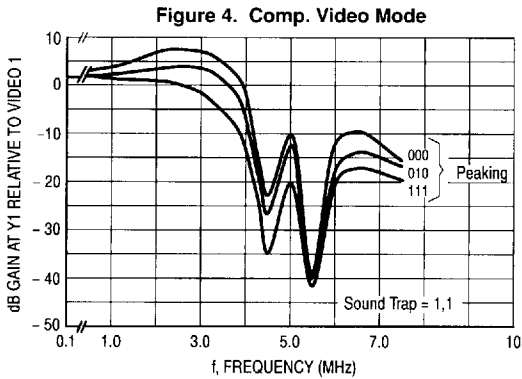

Luma Frequency Response (17.7 MHz) Crystal, (5.5/5.75 MHz) Sound Trap

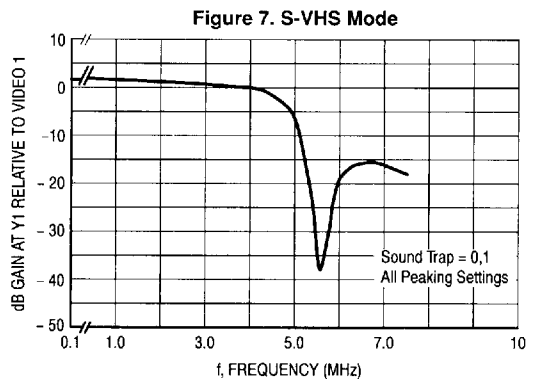
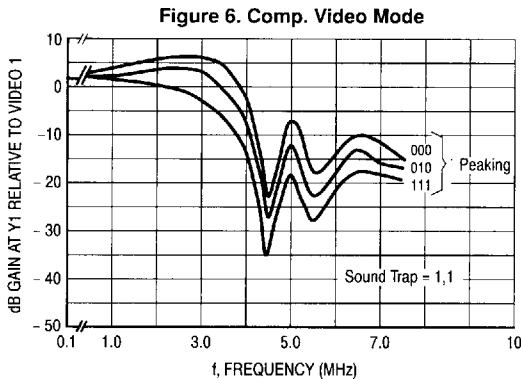

MC44011

Luma Frequency Response (17.7 MHz) Crystal, (6.0 MHz) Sound Trap

Figure 8. Comp. Video Mode

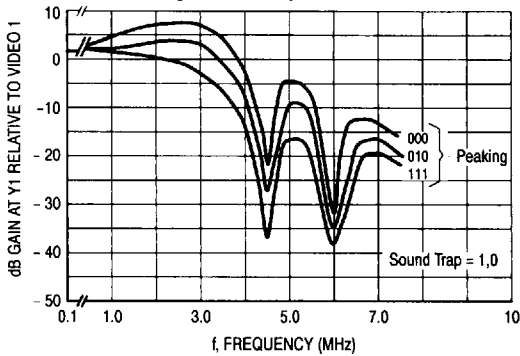
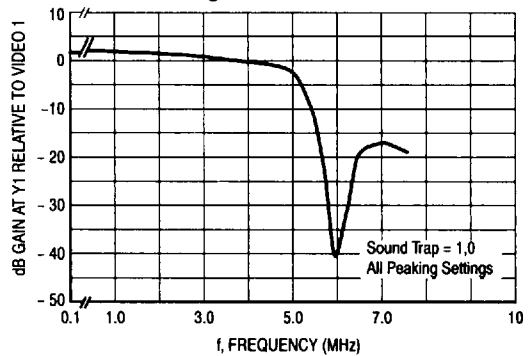

Figure 9. S-VHS Mode



Luma Frequency Response (17.7 MHz) Crystal, (6.5 MHz) Sound Trap

Figure 10. Comp. Video Mode

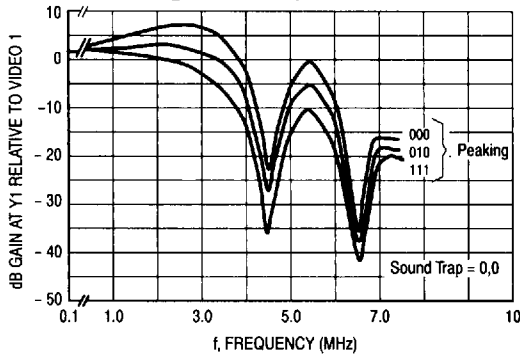

Figure 11. S-VHS Mode

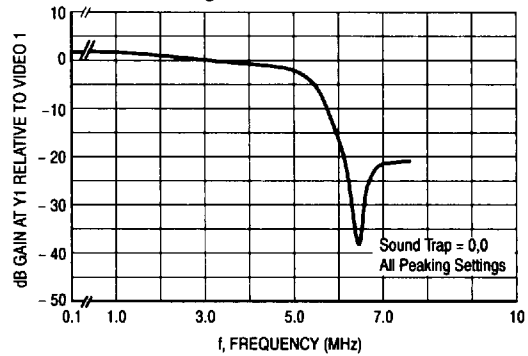

Figure 12. (3.58 MHz) Chroma Notch

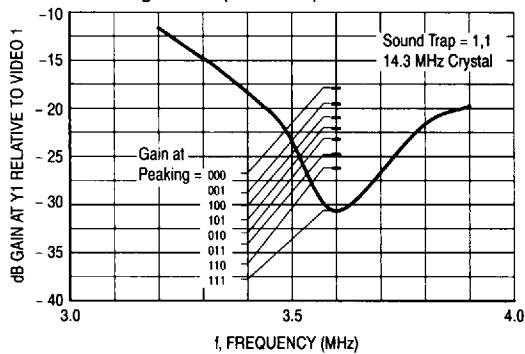
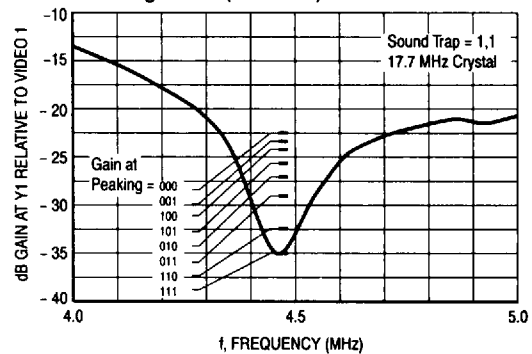

Figure 13. (4.43 MHz) Chroma Notch



MC44011

(4.5 MHz) Sound Trap

Figure 14. Comp. Video Mode

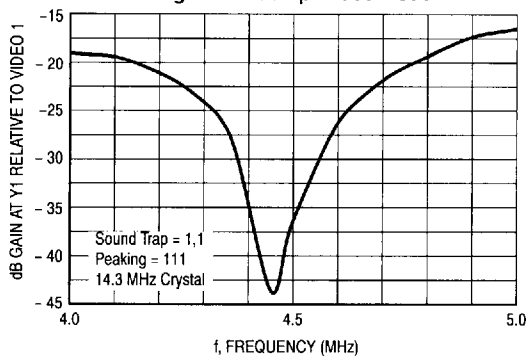
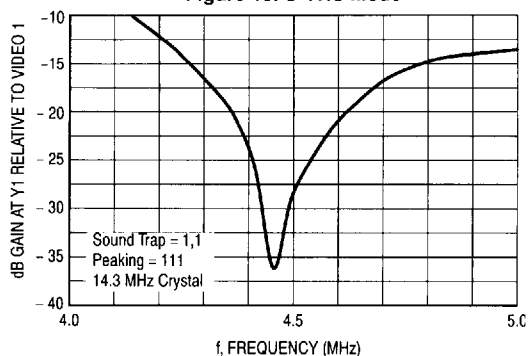

Figure 15. S-VHS Mode



(5.5 MHz) Sound Trap

Figure 16. Comp. Video Mode

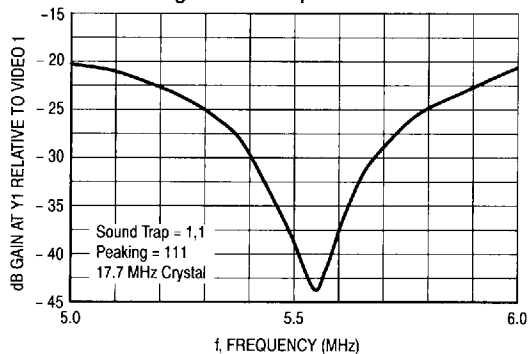
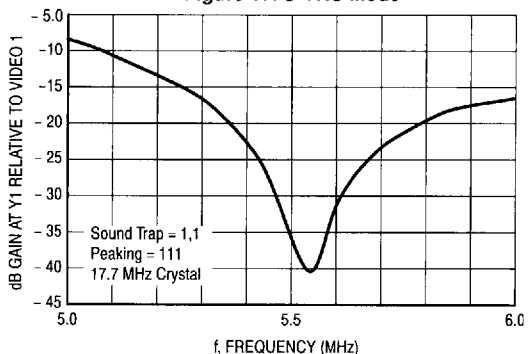

Figure 17. S-VHS Mode



(5.5 + 5.75 MHz) Sound Trap

Figure 18. Comp. Video Mode

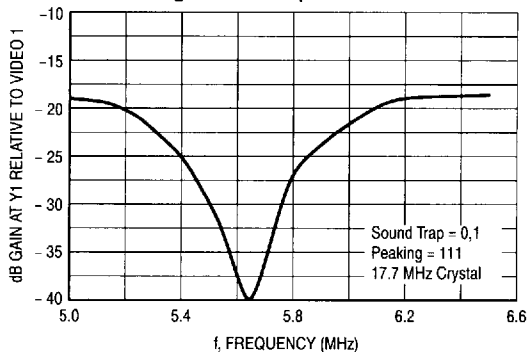
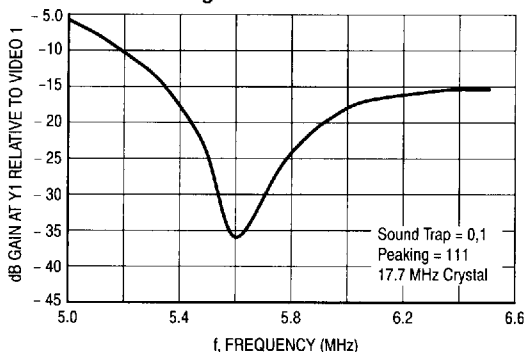

Figure 19. S-VHS Mode



(6.0 MHz) Sound Trap

Figure 20. Comp. Video Mode

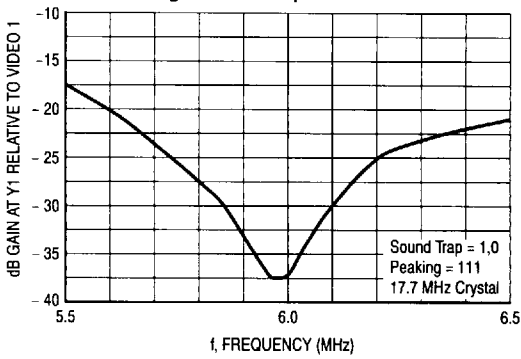
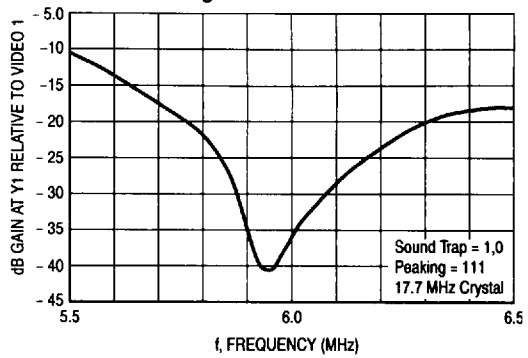

Figure 21. S-VHS Mode



(6.5 MHz) Sound Trap

Figure 22. Comp. Video Mode

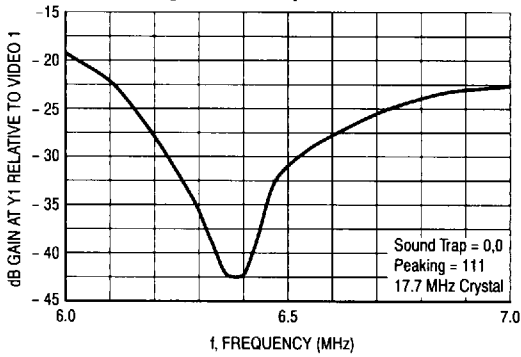

Figure 23. S-VHS Mode

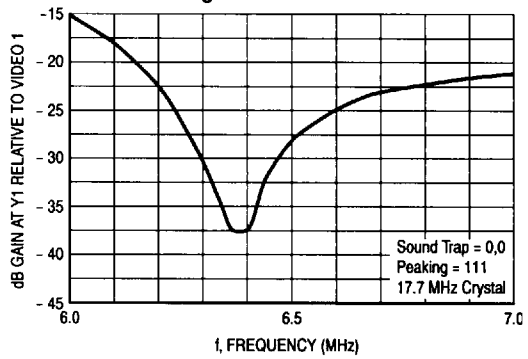
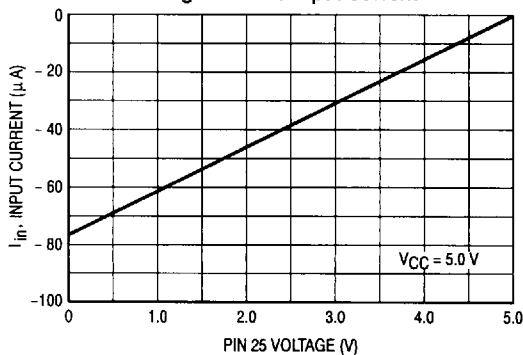
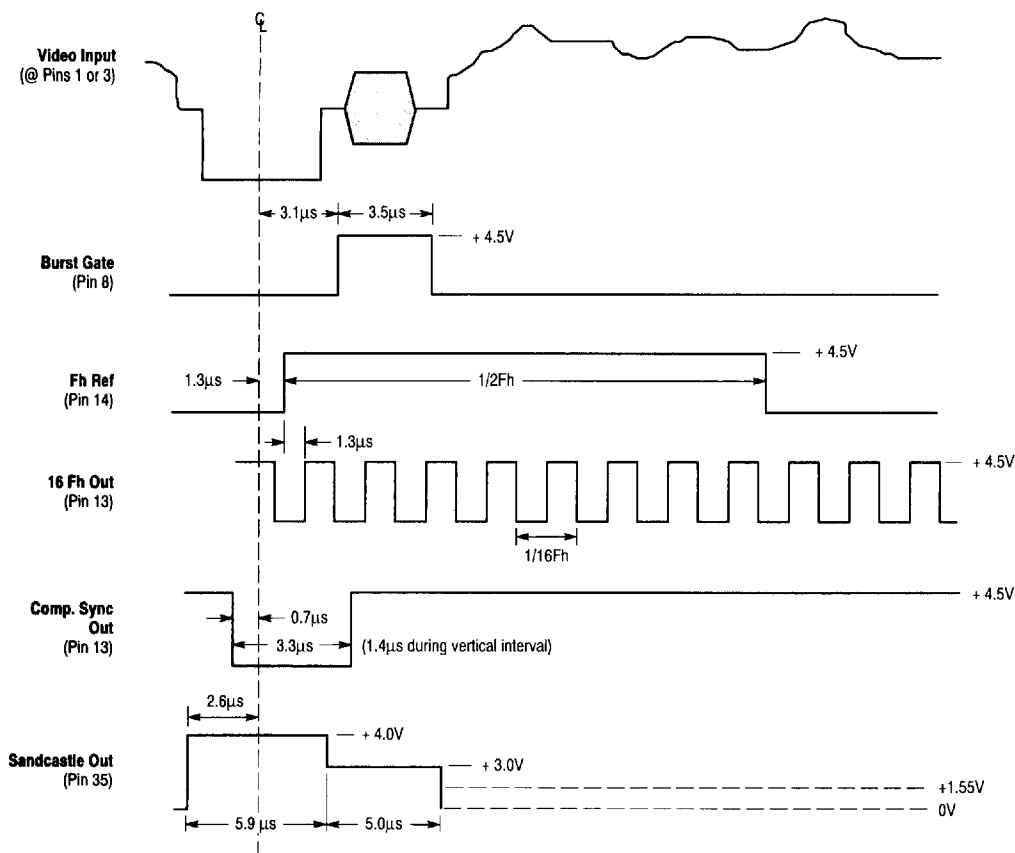

Figure 24. FC Input Current



MC44011

Figure 25. Horizontal PLL1 Timing/Composite Video Inputs



NOTE: In above waveforms, all timing is referenced to the center of the incoming Sync Pulse at Pin 1 or 3. Above timings based on a 4.6 μs wide sync pulse. Lower two levels of Sandcastle output alternate, based on video system in effect. All timings are nominal, and apply to both PAL and NTSC signals.

Figure 26. Horizontal PLL1 Noise Gate and Filter Pin

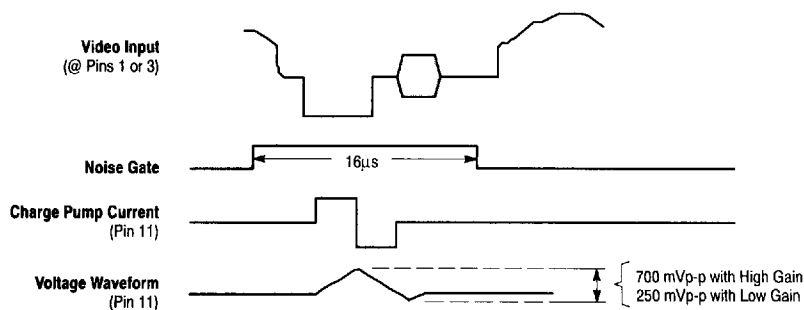

MC44011

Figure 27. Horizontal PLL1 Timing/R, G, B and Y2 Inputs

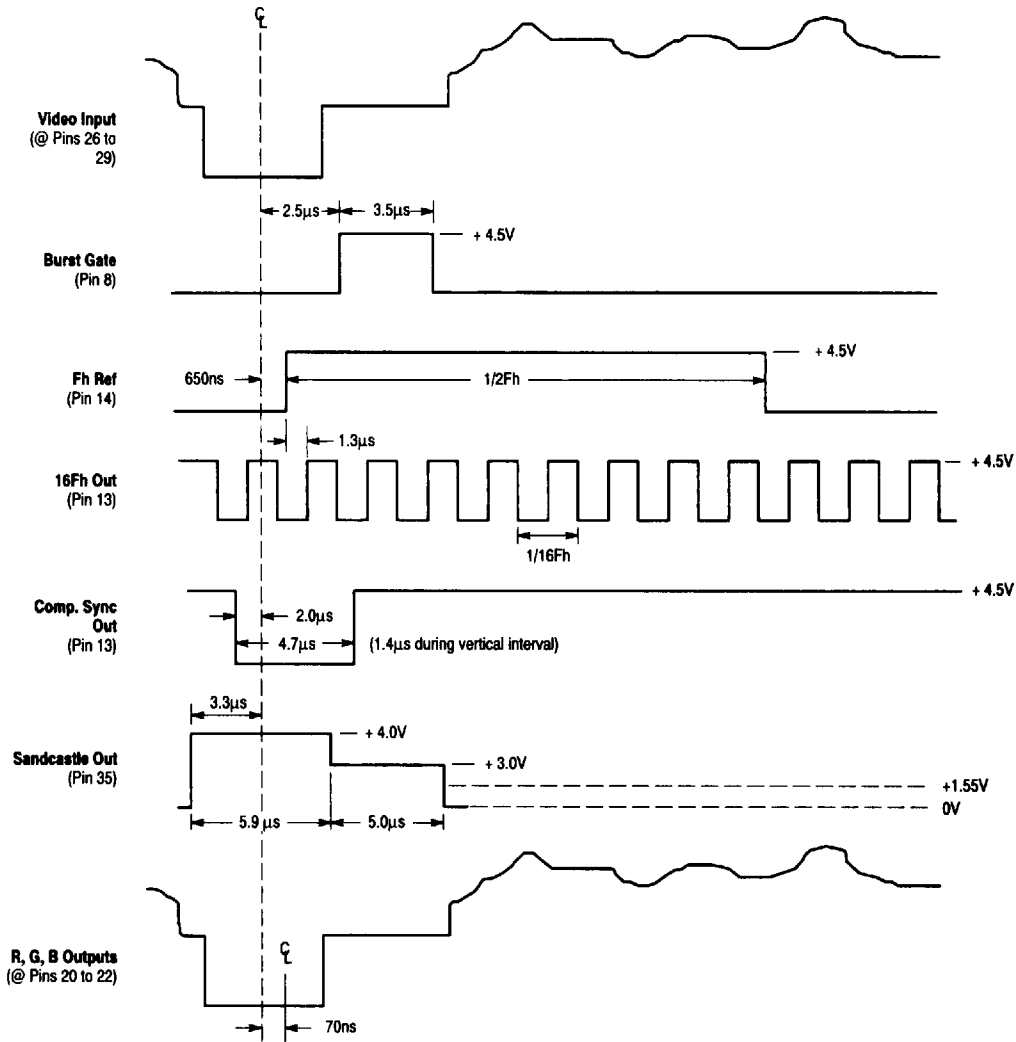

NOTE: In above waveforms, all timing is referenced to the center of the incoming Sync Pulse at Pin 26 to 28, or 29. Above timings based on a 4.6 μ s wide sync pulse. Lower two levels of Sandcastle output alternate, based on video system in effect.

Figure 28. System Timing/Video Inputs to RGB Outputs

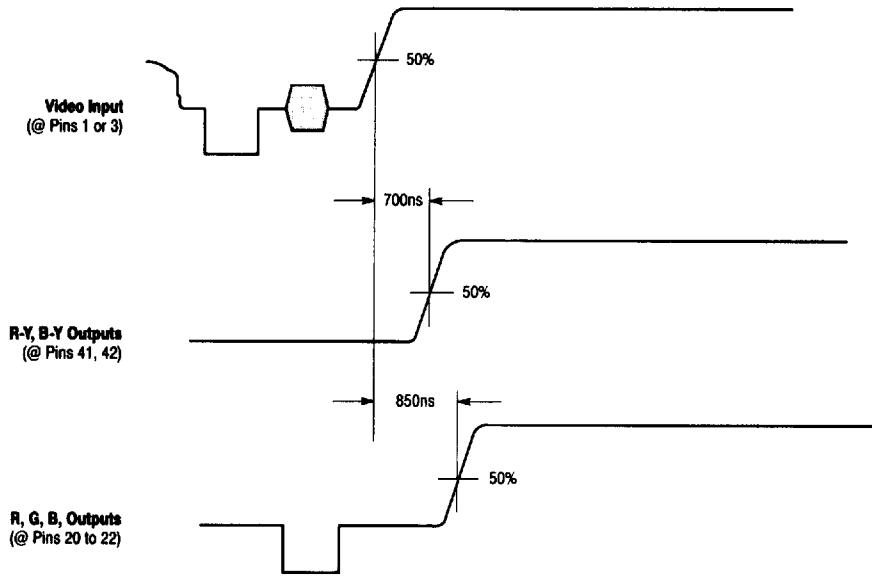

Figure 29. Fast Commutate Timing

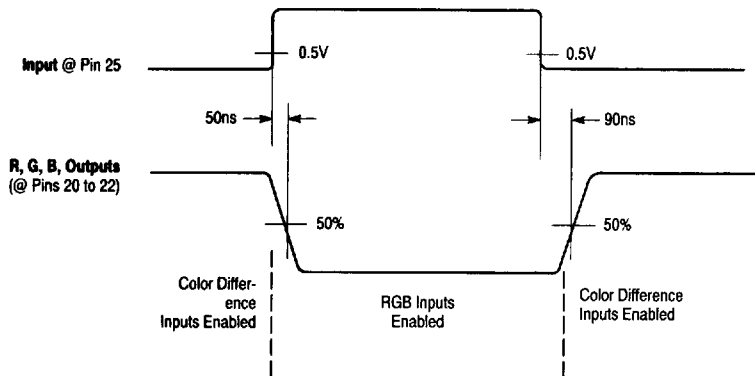
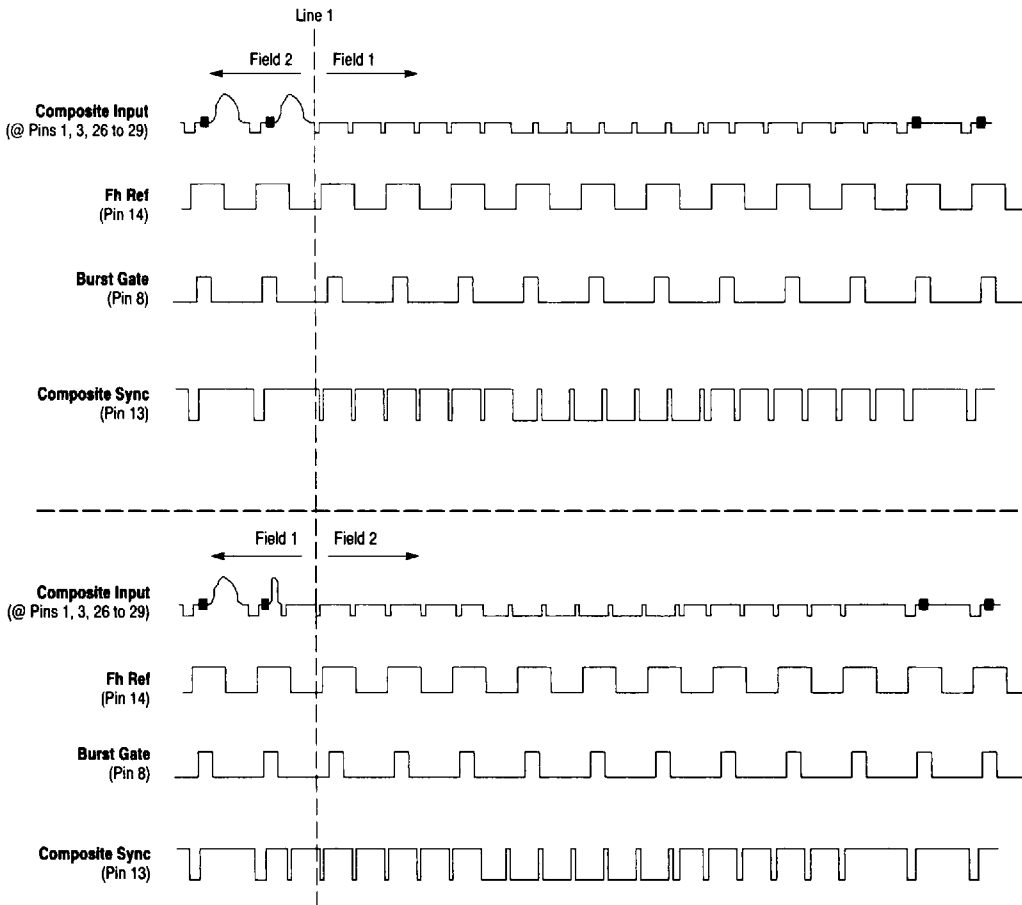

Figure 30. Horizontal Outputs versus Fields (NTSC System)



MC44011

Figure 31. Horizontal Outputs versus Fields (PAL System)

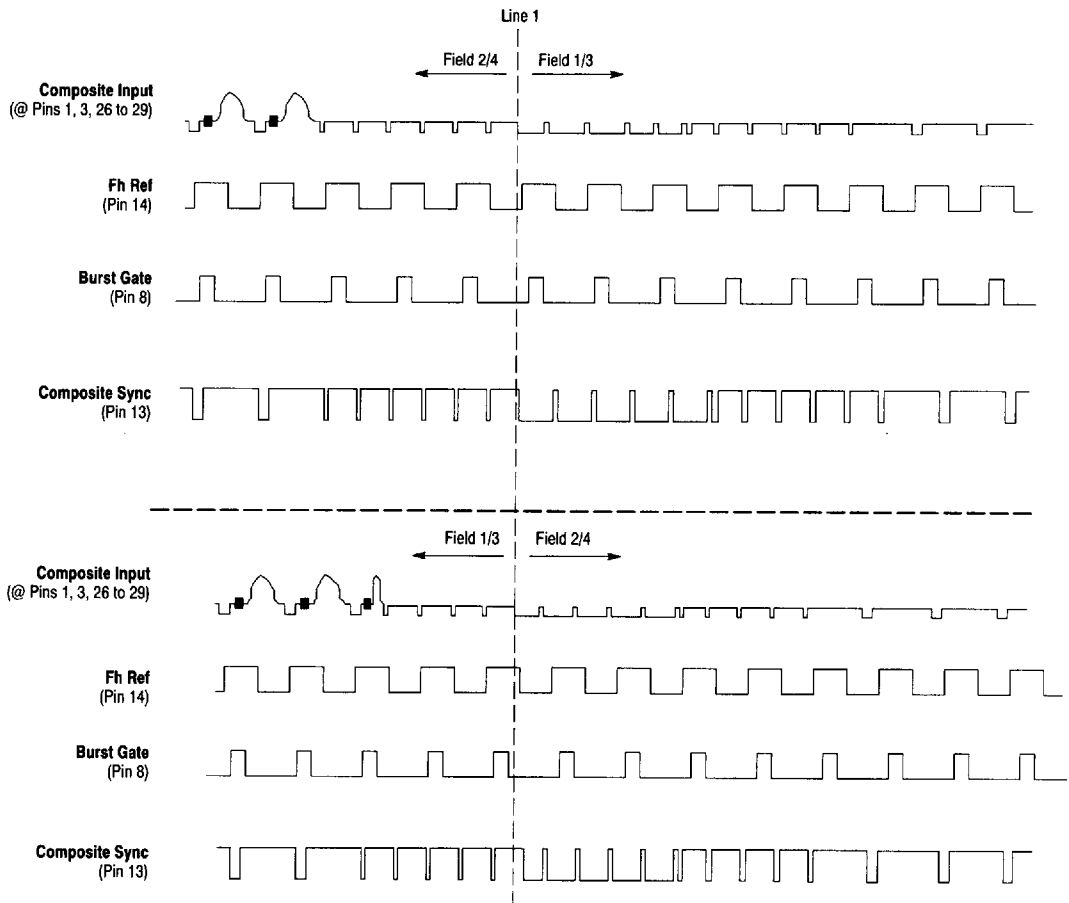
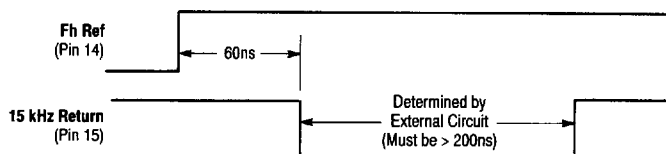
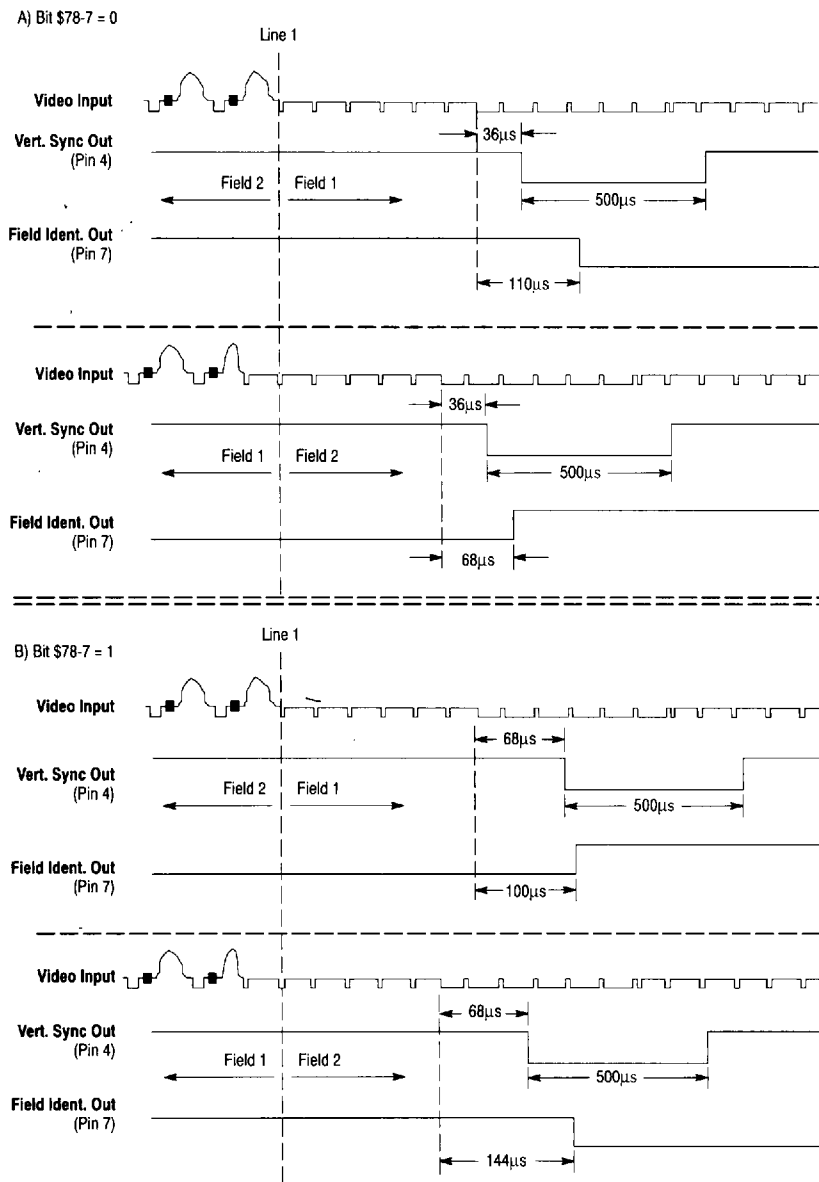

Figure 32. Horizontal PLL2 Timing



MC44011

Figure 33. Vertical Timing (NTSC System)



MC44011

Figure 34. Vertical Timing (PAL System)

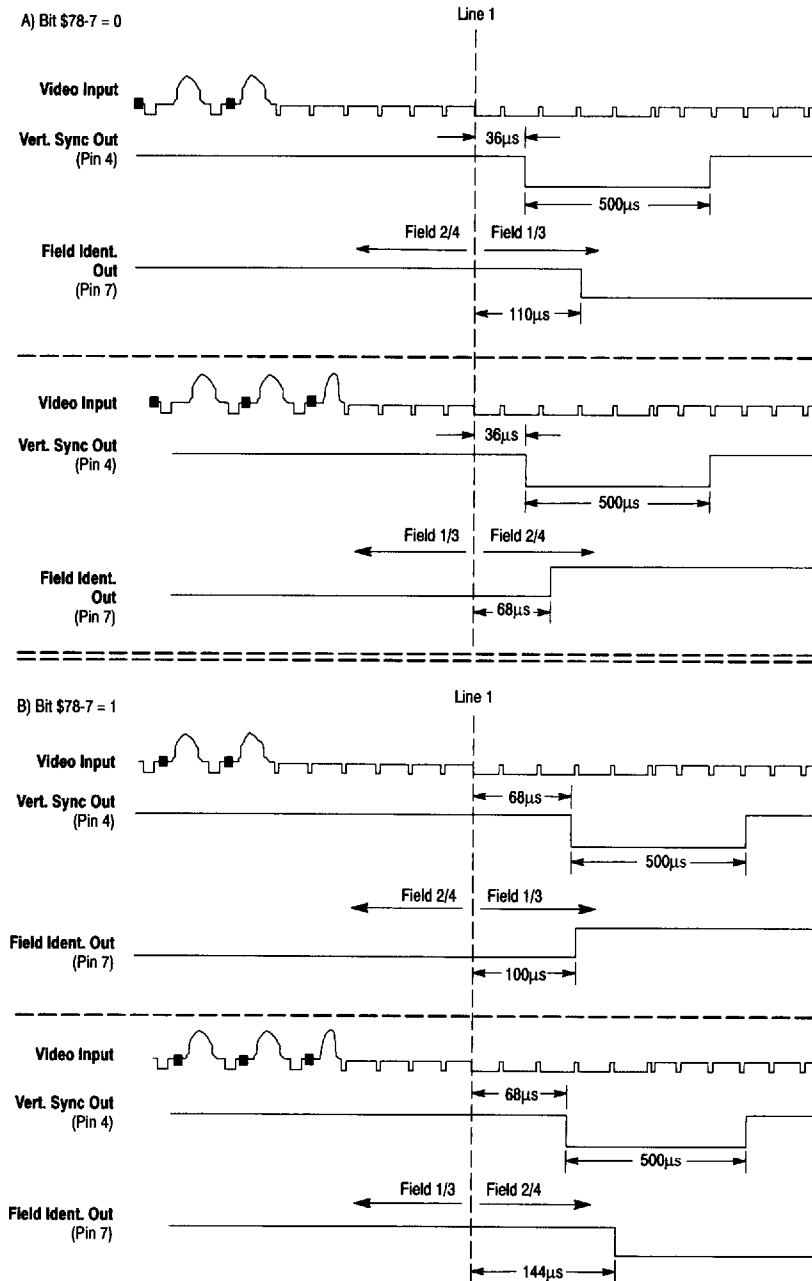

MC44011

FUNCTIONAL DESCRIPTION

Introduction

The MC44011, a member of the MC44000 Chroma 4 family, is a composite video decoder which has been tailored for applications involving multimedia, picture-in-picture, and frame storage (although not limited to those applications). The first stage of the MC44011 provides color difference signals (R-Y, B-Y, and Y) from one of two (selectable) composite video inputs, which are designed to receive PAL, NTSC, and S-VHS (Y,C) signals. The second stage provides either RGB or YUV outputs from the first stage's signals, or from a separate (internally selectable) set of RGB inputs, permitting an overlay function to be performed. Adjustments can be made to saturation; hue; brightness; contrast; brightness balance; contrast balance; U and V bias; subcarrier phase; and color difference gain ratio.

The above mentioned video decoding sections provide the necessary luma/delay function, as well as all necessary filters for sound traps, luma/chroma separation, luma peaking, and subcarrier rejection. External tank circuits and luma delay lines are not needed. For PAL applications, the MC44140 chroma delay line provides the necessary line-by-line corrections to the color difference signals required by that system.

The MC44011 provides a pixel clock to set the sampling rate of external A/D converters. This pixel clock, and other horizontal frequency related output signals, are phase-locked

to the incoming sync. The VCO's gain is adjustable for optimum performance. The MC44011 also provides vertical sync and field identification (Field 1, Field 2) outputs.

Selection of the various inputs, outputs, and functions, as well as the adjustments, is done by means of a two-wire I²C interface. The basic procedure requires the microprocessor system to read the internal flags of the MC44011, and then set the internal registers appropriately. This I²C interface eliminates the need for manual controls (potentiometers) and external switches. All of the external components for the MC44011, except for the two crystals, are standard value resistors and capacitors, and can be non-precision.

(The DACs mentioned in the following description are 6-bits wide. The settings mentioned for them are given in decimal values of 00 to 63. These are not hex values.)

PAL/NTSC/S-VHS Decoder

A block diagram of this decoder section is shown in Figure 35. This section's function is to take the incoming composite video (at Pins 1 or 3), separate it into luma and chroma information, determine if the signal is PAL or NTSC (for the flags), and then provide color difference and luma signals at the outputs. If the input is S-VHS, the luma/chroma separation is bypassed, but the other functions are still in effect.

Figure 35. PAL/NTSC/S-VHS Decoder Block Diagram

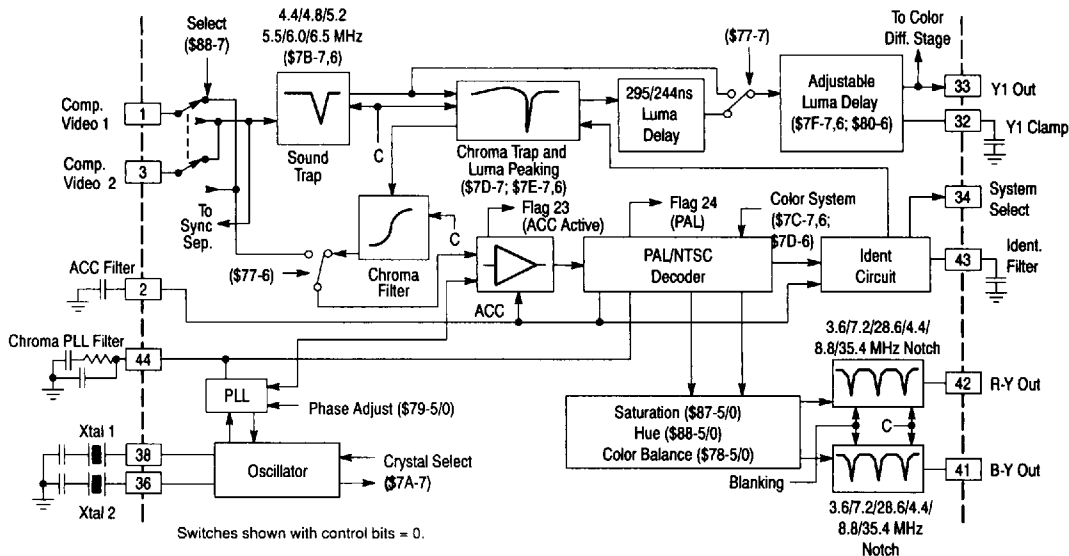

MC44011

Inputs

The inputs at Pins 1 and 3 are high impedance inputs designed to accept standard 1.0 V_{p-p} positive video signals (with negative going sync). The inputs are to be capacitor-coupled so as not to upset the internal DC bias. When normal composite video is applied, the desired input is selected by Bit \$88-7. Bits \$77-6 and \$77-7 must be set to 0 so that their switches are as shown in Figure 35. The selected signal passes through the sound trap, and is then separated by the chroma trap and the chroma (high pass) filter.

When S-VHS signals (Y,C) are applied to the two inputs, Bit \$88-7 is used to direct the luma information to the sound trap, and the chroma information to the ACC circuit (Bit \$77-6 must be set to a Logic 1). Bit \$77-7 is normally set to a Logic 1 in this mode to bypass the first luma delay line and the chroma trap, but it can be left 0 if the additional delay is desired.

Sound Trap

The sound trap will filter out any residual sound subcarrier at the frequency selected by control bits T1 and T2 according to Table 3. The accuracy of the notch frequency is directly related to the selected crystal frequency.

Table 3. Sound Trap Frequency

Crystal Frequency	T1 (\$7B-7)	T1 (\$7B-6)	Notch Frequency
17.73 MHz	0	0	6.5 MHz
17.73 MHz	0	1	5.5 + 5.75 MHz
17.73 MHz	1	0	6.0 MHz
	1	1	5.5 MHz
14.32 MHz	0	0	5.25 MHz
14.32 MHz	0	1	4.44 + 4.64 MHz
14.32 MHz	1	0	4.84 MHz
	1	1	4.44 MHz

Code 01 (for T1, T2) is used to widen the band rejection where stereo is in use. Typical rejection is 30 dB.

ACC and PAL/NTSC Decoder

The chroma filter bandpass characteristics (3.58 or 4.43 MHz) is determined by the selected crystal. The output of the chroma filter is sent to the ACC circuit which detects the burst signal, and provides automatic gain control once the crystal oscillator has achieved phase lock-up to the burst. The DC voltage at Pin 2 is ≈ 1.5 to 2.0 V. This will occur if the burst amplitude exceeds 30 mV_{p-p}, and if the correct crystal is selected (Bit \$7A-7). A 17.734472 MHz crystal is required for PAL, and a 14.31818 MHz crystal is required for NTSC. When Flag 23 is high, it indicates that the crystal's PLL has locked up, and the ACC circuit is active, providing automatic gain control. A small amount of phase adjustment ($\approx \pm 5^\circ$) of the crystal PLL, for color correction, can be made with control DAC \$79-5/0. Pin 2 is the filter for the ACC loop, and Pin 44 is the filter for the crystal oscillator PLL.

The PAL/NTSC decoder then determines if the signal is PAL or NTSC by looking for the alternating phase characteristic of the PAL burst. When Flag 24 is high, PAL has been detected. Bits SSA, SSB, SSC, and SSD (Table 4) must then be sent to the decoder to set the appropriate decoding method.

Table 4. Color System Select

SSA (\$7C-6)	SSB (\$7D-6)	SSC (\$7C-7)	SSD (\$7A-6)	Color System
0	0	0	0	Not Used
0	1	0	0	PAL
1	0	0	0	NTSC
1	1	0	0	Color Kill
X	X	1	0	External

Upon receiving the SSA to SSD bits, the decoder provides the correct color difference signals, and with the Identification circuit, provides the correct level at the System Select output (Pin 34). This output is used by the MC44140 delay line.

The color kill setting (SSA = SSB = 1) should be used when the ACC flag is 0, when the color system cannot be properly determined, or when it is desired to have a black-and-white output (the ACC circuit and flag will still function if the input signal has a burst signal). The "External" setting (SSC = 1) is used when an external (alternate) source of color difference signals are applied to the MC44140 delay line. (See Miscellaneous Applications Information for more details.)

Color Difference Controls and Outputs

The color difference signals (R-Y, B-Y) from the PAL/NTSC decoder are directed to the saturation, hue and color balance controls, and then through a series of notch filters before being output at Pins 41 and 42. Blanking and clamping are applied to these outputs.

The saturation control DAC(\$87-5/0) varies the amplitude of the two signals from 0 V_{p-p} (DAC setting = 00), to a maximum of ≈ 1.8 V_{p-p} (at a DAC setting of 63). The maximum amplitude (without clipping) is ≈ 1.5 V_{p-p}, but a nominal setting is ≈ 1.3 V_{p-p} at a DAC setting of 15.

The hue control (\$88-5/0) varies the relative amplitude of the two signals to provide a hue adjustment. The nominal setting for this DAC is 32.

The color balance control (\$78-5/0) provides a fine adjustment of the relative amplitude of the two outputs. This provides for a more accurate color setting, particularly when NTSC signals are decoded. The nominal setting for this DAC is 32, and should be adjusted before the hue control is adjusted.

The notch filters provide filtering at the color burst frequency, and at 2x and 8x that frequency. Additionally, blanking and clamping (derived from the horizontal PLL) are applied to the signals at this stage. The nominal output DC level is ≈ 2.0 to 2.5 V_{dc}, and the load applied to these outputs should be >10 k Ω . Sync is not present on these outputs.

MC44011

Luma Peaking, Delay Line, and Y1 Output

When composite video is applied, the luma information extracted in the chroma trap is then applied to a stage which allows peaking at ≈ 3.0 MHz with the 17.7 MHz crystal (≈ 2.2 MHz with the 14.3 MHz crystal). The amount of peaking at Y1 is with respect to the gain at the minimum peaking value (P1, P2, P3 = 111), and is adjustable with Bits \$7D-7, and \$7E-7,6 according to Table 5.

The luma delay lines allow for adjustment of that delay so as to correspond to the chroma delay through this section. Table 6 indicates the amount of delay using the D1-D3 bits (\$7F-7,6, and \$80-6). The delay indicated is the total delay from Pin 1 or 3 to the Y1 output at Pin 33. The amount of delay depends on whether Composite Video is applied, or YC signals (S-VHS) are applied.

The output impedance at Y1 is $\approx 300 \Omega$, and the black level clamp is at $\approx +1.1$ V. Sync is present on this output. Y1 is also internally routed to the color difference stage.

Table 5. Luma Peaking

P1 (\$7D-7)	P2 (\$7E-6)	P3 (\$7E-7)	Y1 Peaking
0	0	0	+ 9.5 dB
0	0	1	+ 8.5
1	0	0	+ 7.7
1	0	1	+ 6.5
0	1	0	+ 5.3
0	1	1	+ 3.8
1	1	0	+ 2.2
1	1	1	0

17.7 MHz Crystal, 6.5 MHz Sound Trap, Comp. Video Mode

Table 6. Luma Delay

D1 (\$7F-6)	D2 (\$80-6)	D3 (\$7F-7)	14.3 MHz Crystal		17.7 MHz Crystal	
			Comp. Video (\$77-7 = 0)	S-VHS (\$77-7 = 1)	Comp. Video (\$77-7 = 0)	S-VHS (\$77-7 = 1)
0	0	0	690 ns	395 ns	594 ns	350 ns
0	0	1	760	465	650	406
0	1	0	830	535	707	463
0	1	1	900	605	763	519
1	0	0	970	675	819	575
1	0	1	1040	745	876	632
1	1	0	970	675	819	575
1	1	1	1040	745	876	632

Color Difference Stage and RGB/YUV Outputs

A block diagram of this section is shown in Figure 36. This section's function is to take the color difference input signals (Pins 30,31), or the RGB inputs (Pins 26 to 28), and output the information at Pins 20 to 22 as either RGB or YUV.

The inputs (on the left side of Figure 36) are analog RGB, or color difference signals (R-Y and B-Y) with Y1 or Y2 as the luma component. Pin 25 (Fast Commutate) is a logic level

input, used in conjunction with RGB EN (Bit \$80-7), to select the RGB inputs or the color difference inputs. The outputs (Pins 20 to 22) are either RGB or YUV, selected with Bit \$82-7. The bit numbers adjacent to the various switches and gates indicate the bits used to control those functions. Table 7 indicates the modes of operation.

Table 7. Color Difference Input/Output Selection

FC	RGB EN \$80-7	YX EN \$82-6	YUV EN \$82-7	Function
1	0	0	0	RGB inputs, RGB outputs, no saturation control
1	0	1	0	RGB inputs, RGB outputs, with saturation control
1	0	1	1	RGB inputs, YUV outputs, with saturation control
1	0	0	1	Not usable
FC Low and/or RGB EN Hi		X	0	R-Y, B-Y inputs, RGB outputs. Y1 or Y2 must be selected
FC Low and/or RGB EN Hi		X	1	R-Y, B-Y inputs, YUV outputs. Y1 or Y2 must be selected

MC44011

In addition to Table 7, the following guidelines apply:

- a) To select the RGB inputs, both FC must be high and RGB EN must be low. Therefore, the RGB inputs can be selected either by the I²C bus by leaving FC permanently high, or by the FC input by leaving Bit \$80-7 permanently low. For overlay functions, where high speed, well controlled switching is necessary, the FC pin must be the controlling input.
- b) When the R-Y, B-Y inputs are selected, either Y1 or Y2 must be selected, and the other must be deselected. The YX input is automatically disabled in this mode.
- c) In applications where the color difference inputs are

obtained from the NTSC/PAL decoder (from a composite video signal), Y1 is used. The Y2 input is normally used where alternately sourced color difference signals are applied, either through the MC44140 delay line, or through other external switching to Pins 30 and 31.

In Figure 36, the bit numbers followed by “- 0/5” indicate DAC operated controls (contrast, brightness, etc.), which are controlled by the I²C bus. The DACs have 6-bit resolution, allowing 64 adjustment steps. Table 8 provides guidelines on the DAC operation.

Table 8. DAC Operation – Color Difference Section

Function	Bits	RGB Outputs (\$82-7 = 0)	YUV Outputs (\$82-7 = 1)
Brightness	\$84-0/5	Affects DC black and maximum levels of the three outputs, but not the clamp level, nor the amplitude.	Affects DC black and white levels of the Y output only, but not the clamp level, nor the amplitude.
Δ DC – Red Δ DC – Blue	\$85-0/5 \$83-0/5	Fine tune the Red and Blue brightness levels.	Allows a small amount of color tint control (not to be confused with hue).
Contrast	\$81-0/5	Provides gain adjustment (black-to-white) of the three outputs.	Provides gain adjustment of the three outputs.
Δ Gain – Red Δ Gain – Blue	\$82-0/5 \$80-0/5	Fine tune the Red and Blue contrast levels.	Fine tune of the U and V gain levels.
V DC U DC	\$7E-0/5 \$7D-0/5	Must be set to 00.	Should nominally be set to 32. This sets the DC level of the U and V outputs at ≈ mid-scale.
Main Saturation	\$86-0/5	Affects color saturation, except when the RGB inputs bypass this section (YX EN = 0).	Affects color saturation levels of the UV outputs. Does not affect the Y output.

9

Figure 36. Color Difference Stage and Outputs

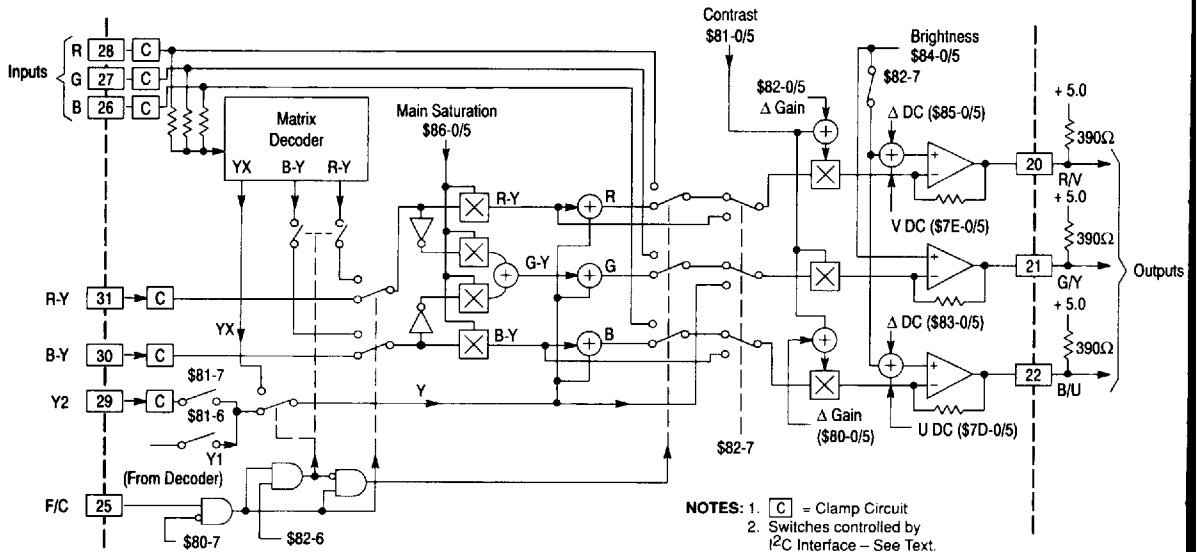

MC44011

The RGB and Y2 inputs are designed to accept standard 1.0 Vp-p analog video signals. They are not designed for TTL level signals. The color difference inputs are designed to accept signals ranging up to 1.8 Vp-p. All signals are to be capacitor-coupled as clamping is provided internally. Input impedance at these six pins is high.

For applications involving externally supplied color difference signals, sync can be supplied on the luma input (Y2), or it can be supplied separately at the RGB inputs. Where the color difference signals are obtained from the NTSC/PAL decoder, sync is provided to this section on the internal Y1 signal. See Sync Separator section for more details on injecting sync into the MC44011.

Sync is present on all three outputs in the RGB mode, and on the Y output only (Pin 21) in the YUV mode.

The Fast Commutate input (FC, Pin 25) is a logic level input with a threshold at ≈ 0.5 V. Input impedance is ≈ 67 k Ω , and the graph of Figure 24 shows the input current requirements. Propagation delay from the FC pin to the RGB/YUV outputs is ≈ 50 ns when enabling the RGB inputs, and ≈ 90 ns when disabling the inputs. (See Figure 29 Fast Commutate Timing diagram.) If Pin 25 is open, that is equivalent to a Logic 1, although good design practices dictate that inputs should never be left open. The voltage on this pin should not be allowed to go more the 0.5 V above VCC2 or below ground.

The three outputs (Pins 20 to 22) are open-collector, requiring an external pull-up. A representative schematic is shown in Figure 37.

The output amplitude can be varied from 100 mVp-p to 3.0 Vp-p by use of the contrast and saturation controls. Any output load to ground should be kept larger than 1.0 k Ω . In the RGB mode, DACs \$7D and \$7E should be set to 00, which results in clamping levels of $\approx +1.4$ Vdc. In the YUV mode, DACs \$7D and \$7E should be set to 00, which results

Figure 37. Output Stage

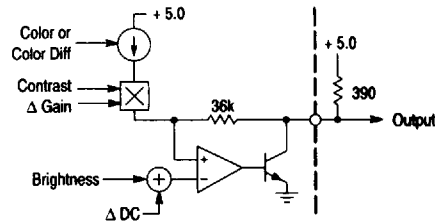

in clamping levels of $\approx +1.4$ Vdc. In the YUV mode, the DACs should be set to 32 to bias the U and V outputs to $\approx +2.3$ V. The Y output clamp will remain at $\approx +1.4$ V in the YUV mode.

Horizontal PLL (PLL1)

PLL1 (shown in Figure 38) provides several outputs which are phase-locked to the incoming horizontal sync. In normal operation, the two switches at the left side of Figure 38 are as shown, and (usually) the transistor at Pin 12 is off.

The phase detector compares the incoming sync (from the sync separator) to the frequency from the +64 block. The phase detector's output, filtered at Pin 11, controls the VCO to set the correct frequency (≈ 1.0 MHz) so that the output of the +64 is equal to the incoming horizontal frequency.

The line-locked outputs are:

- 1) **Fh Ref** (Pin 14) – A square wave, TTL levels, at the horizontal frequency, and phase-locked to the sync source according to the timing diagram of Figures 25 and 27.
- 2) **Burst Gate** (Pin 8) – This is a positive going pulse, TTL levels, coincident with the burst signal. See the timing diagram of Figures 25 and 27.

Figure 38. Horizontal PLL (PLL1)

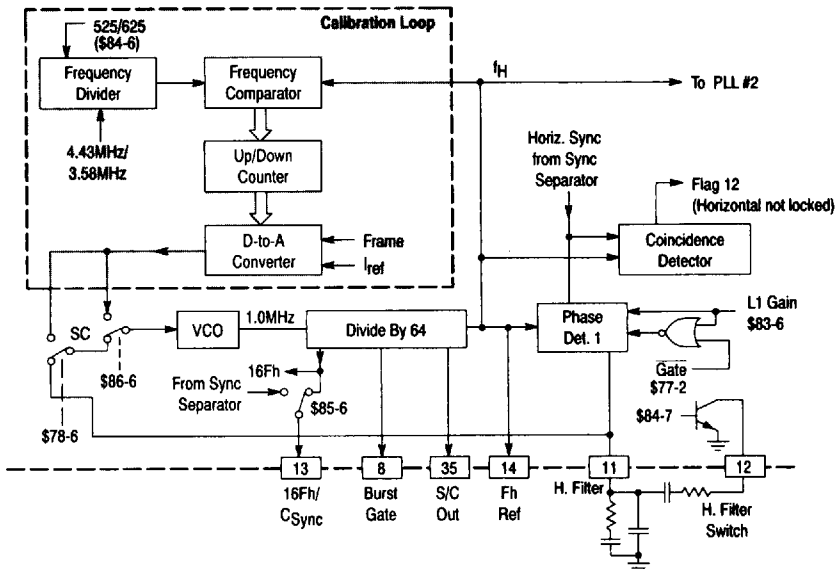

MC44011

- 3) **Sandcastle Output** (Pin 35) – This is a multilevel output, at the horizontal frequency, used by the MC44140 delay line. See the timing diagram of Figures 25 and 27.
- 4) **16Fh/CSync** (Pin 13) – This is a dual purpose output, TTL levels, user selectable. When Bit \$85-6 is set to 0, Pin 13 is a square wave at 16x the horizontal frequency (250 kHz for PAL, \approx 252 kHz for NTSC). When Bit \$85-6 is set to 1, Pin 13 is negative composite sync, derived from the internal sync separator. See the timing diagram of Figures 25 and 27.

The first three outputs mentioned above, and Pin 13 when set to 16 Fh, are consistent, and do not change duty cycle or wave shape during the vertical sync interval. These four outputs will also be present regardless of the presence of a video signal at the selected input.

When Pin 13 is set to CSync output, it follows the incoming composite sync format. If there is no video signal present at the selected input, this output will be a steady logic high.

Loading on these pins should not be less than 2.0 k Ω to either ground or + 5.0 V.

Pin 11 is the filter for the PLL, and requires the components shown in Figure 38, and with the values shown in the application circuit of Figure 42. Pin 12 is a switch which allows the filtering characteristics at Pin 11 to be changed. Switching in the additional components (set \$84-7 = 1) increases the filter time constant, permitting better performance in the presence of noisy signals.

The gain of the phase detector may be set high or low, depending on the jitter content of the incoming horizontal frequency, by using Bit \$83-6. Broadcast signals usually have a very stable horizontal frequency, in which case the low gain setting (\$83-6 = 0) should be used. When the video source is, for example, a VCR, the high gain setting may be preferable to minimize instability artifacts which may show up on the screen.

The gating function (\$77-2) provides additional control where the stability of the incoming horizontal frequency is in question. With this bit set to 0, gating is in effect, causing the phase detector to not respond to the incoming sync pulses during the vertical interval. This reduces disturbances in this PLL due to the half-line pulses and their change in polarity. The gating may be disabled by setting this bit to 1 where the timing of the incoming sync is known to be stable. The gating cannot be enabled if the phase detector gain is set high (\$83-6 = 1).

Calibration Loop

The calibration loop (upper left portion of Figure 38) maintains a near correct frequency of this PLL in the absence of incoming sync signals. This feature minimizes re-adjustment and lock time when sync signals are re-applied. The calibration loop is similar to the PLL function, receiving one frequency from the crystal (either 4.43 MHz or 3.58 MHz) divided down to a frequency similar to the standard horizontal frequency. Bit \$84-6 is used to set the frequency divider to the correct ratio, depending on which crystal is selected (see Table 9). The output of the frequency comparator operates an up/down counter, which in turn sets

the D-to-A converter to drive the VCO through switch Sc. The resulting frequency at the output of the divide-by-64 block is then fed to the frequency comparator to complete the loop.

When a sync signal is not present at Phase Detector #1, and at the Coincidence Detector, as indicated by the coincidence detector's output (Flag 12), Bit \$78-6 should be set to 0. This will cause the switch (Sc) to transfer to the D-to-A converter for two lines (lines 4, 5) in each vertical field, and will maintain the PLL1 at a frequency near the standard horizontal frequency (between 14 to 16 kHz). When lock to an incoming sync is established, Bit \$78-6 may be set to 1, disabling the periodic recalibration function, or it may be left set to 0.

If a more accurate horizontal frequency is desired in the absence of an input signal, Bit \$86-6 can be set to 1 (and Bit \$84-6 set according to Table 9). This holds the horizontal frequency to \approx 15.7 kHz. In this mode, Flag 12 will stay 0, as the PLL will not be able to lock-up to a newly applied external signal. To reset the system, set \$86-6 to 0, write \$00 to register \$00, and then check Flag 12 to determine when the loop locks to an incoming signal.

Table 9. Calibration Loop

Crystal	Set Bit \$84-6 to
14.3 MHz	1
17.7 MHz	0

On initial power up, Bit \$86-6 (PLL1 EN) is automatically set to 1, engaging the calibration loop continuously. This condition will remain until this bit is set to 0, and \$00 is written to register \$00, as part of the initialization routine.

Pixel Clock PLL (PLL2)

The second PLL, depicted in Figure 39, generates a high frequency clock which is phase-locked to the horizontal frequency.

Figure 39. Pixel Clock PLL (PLL2)

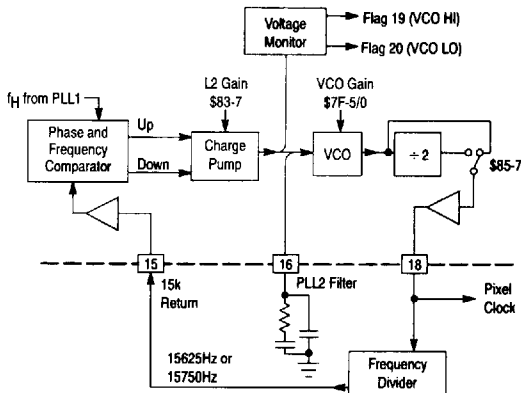

MC44011

The phase and frequency comparator receive inputs from PLL1 (f_H , the horizontal frequency), and the frequency returned from the external divider. Any difference between these two signals causes the Up or Down output to change the charge pump's timing. The charge pump output is composed of two equal current sources which alternately source and sink current to the filter at Pin 16. The voltage at Pin 16 (which is the input to the VCO) is therefore determined by the relative timing of those two current sources, and the filter characteristics. A coarse control of the loop gain is set with Bit \$83-7. Low gain is obtained by setting this bit to a 1, which sets the charge pump's output current sources to $\approx \pm 20 \mu\text{A}$. Setting this bit to 0 sets the current sources to $\approx \pm 50 \mu\text{A}$, or high gain.

Depending on the output frequency desired, and whether or not a 50-50 square wave is needed at the pixel clock, the $\div 2$ may be engaged (Bit \$85-7). Generally, the $\div 2$ should not be engaged for high frequencies, and should be engaged for low frequencies, so as to keep the VCO's input voltage in a comfortable range (between 1.7 and 3.3 V). If the input voltage is outside this range, Flag 19 or 20 will switch high, indicating the need to fine tune the VCO's gain (control DAC \$7F). The usable adjustment range for this DAC is 00 to ≈ 50 . Settings of 51 to 62 will generally produce non-square wave outputs, and can be unstable. A setting of 63 will shut off the VCO, which should be done if the pixel clock is not used. When not used, Pin 18 will be at a constant low level.

The pixel clock frequency is equal to the horizontal frequency (f_H) \times the frequency divider ratio. The frequency divider can be made up of programmable counters (e.g. MC74F161A Applications Information), or it can be integrated into another device (e.g., an ASIC). The returned signal to Pin 15 must be TTL/CMOS logic levels, and must have a low time of $> 200 \text{ ns}$. The phase comparator will phase-lock the falling edge of the returned signal with the rising edge of the f_H signal at Pin 14 (see Figure 32).

Vertical Decoder

The vertical decoder section, depicted in Figure 40, provides a vertical sync pulse and a field identification signal, as well as flags which indicate if vertical lockup has occurred, and if the number of horizontal lines per frame is greater or less than 576.

Inputs to this section consists of the composite sync from the sync separator, and horizontal related signals from the horizontal PLL (PLL1).

Figure 40. Vertical Decoder

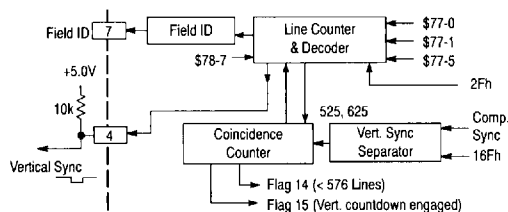

The sync output (Pin 4) is an active low signal which starts after the horizontal half-line sync pulses change polarity (see Figures 33 and 34). The pulse width is nominally 500 μs for both PAL and NTSC signals. The position of this sync pulse's leading edge can be altered slightly with Bit \$78-7, but this does not change the pulse width. Since the pulse width is generated digitally by counters, it will not vary with temperature, supply voltage, or manufacturing distribution. The sync output is an open-collector NPN output, requiring an external pull-up resistor. Minimum value for the pull-up is 1.0 k Ω , with 10 k Ω recommended for most applications.

Flag 14 (< 576 lines) is derived from the counter which compares the number of horizontal lines in each frame with a preset value of 576. This flag can be used externally to help determine whether PAL or NTSC signals are being provided to the MC44011. Flag 15 (Vertical countdown engaged) indicates that the vertical decoder has locked-up to the incoming composite sync information for eight consecutive fields (CB1, CA1 = 11).

The operation of the vertical decoder is controlled by Bits \$77-0 and \$77-1, according to Table 10.

Table 10. Vertical Decoder Mode

CB1 (\$77-1)	CA1 (\$77-0)	Vertical Sync Mode
0	0	Force 625
1	0	Force 525
0	1	Injection Lock
1	1	Auto-Count

The Injection Lock mode has a quicker response time, but less noise immunity, than the Auto-Count mode, and is normally used when attempting to lock-up to a new signal (such as when changing video input selection). Flag 15 will not switch high when in this mode. The Auto-Count mode, having a higher noise immunity, should be set once the horizontal PLL is locked-up (by reading Flag 12), and then Flag 15 should be checked after 8 fields for vertical lock-up.

The modes designated Force 525 and Force 625 can be used for those cases where it is desired to force the vertical sync pulse to occur twice every 525 or 625 lines, regardless of the incoming signal. In either of these modes, the MC44011's vertical section will not lock-up to the vertical sync information contained in the incoming composite video signal. If there is no incoming video signal, the vertical sync will still occur every 525 or 625 lines generated by the horizontal PLL. Flag 14 will indicate the number of lines selected, and Flag 15 will be a steady high.

Bit \$77-5 (FSI) is used only in the PAL mode to select the vertical sync output rate. With this bit set to 0, the vertical sync pulses will be synchronized with the composite vertical sync input (every 20 ms). With this bit set to 1, the MC44011 will add a second vertical output sync pulse 10 ms after the one occurring at the vertical interval, giving a vertical sync rate of 100 Hz.

MC44011

The Field ID output (Pin 7) indicates which field is being processed when interlaced signals are applied, but the polarity depends on Bit \$78-7. Table 11 indicates Pin 7 output. When non-interlaced signals are being processed, Pin 7 will be a constant high level when \$78-7 is set to 1, and will be a constant low level when \$78-7 is set to a 0. Loading on Pin 7 should not be less than 2.0 k Ω to either ground or +5.0 V. Figures 33 and 34 indicate the timing.

Table 11. Field ID Output

36/68 μ s (\$78-7)	Field	Field ID (Pin 7)
1	1	High
1	2	Low
0	1	Low
0	2	High

Sync Separator

The sync separator block provides composite sync information to the horizontal PLL, and to various other blocks within the MC44011 from one of several sources. It also provides composite sync output at Pin 13 when Bit \$85-6 = 1. The sync source is selectable via the I²C bus according to Table 12.

Table 12. Sync Source

V _{in} Sync (\$86-7)	Y2 Sync (\$87-7)	RGB Sync (\$88-6)	Sync Source
0	0	0	None
0	0	1	RGB (Pins 26 - 28)
0	1	0	Y2 (Pin 29)
1	X	X	Comp. Video (Pins 1, 3)

Setting Bit \$86-7 to a 1 overrides the other bits, thereby deriving the sync from the composite video input (either Pin 1 or 3) selected by Bit \$88-7.

When RGB is selected, sync information on Pins 26 to 28 is used. Sync may be applied to all three inputs, or to any one with the other two AC grounded. If RGB signals are applied to these pins, sync may be present on any one or all three.

When Y2 is selected, sync information on Pin 29 is used. The sync amplitude applied to any of the above pins must be greater than 100 mV, and it must be capacitor coupled.

This system allows a certain amount of flexibility in using the MC44011, in that if the sync information is not present as part of the applied video signals, sync may be applied to another input. In other words, the input selected for the sync information need not be the same as the input selected for the video information.

SOFTWARE CONTROL OF THE MC44011

I²C Interface

Communication to and from the MC44011 follows the I²C interface arrangement and protocol defined by Phillips Corporation. In simple terms, I²C is a two line, multimaster bidirectional bus for data transfer. See Appendix C for a

description of the I²C requirements and operation. Although an I²C system can be multimaster, the MC44011 never functions as a master.

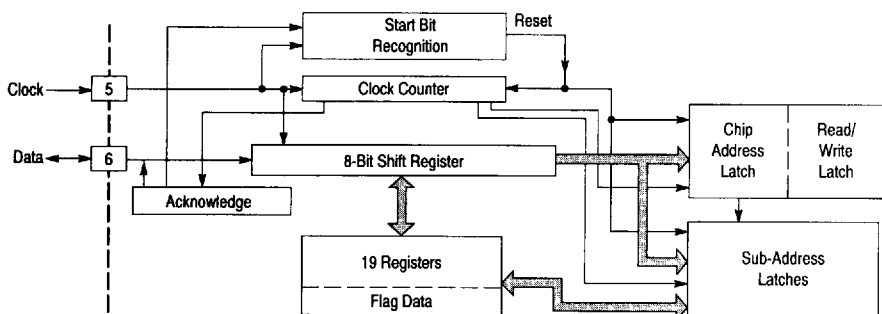
Figure 41. I²C Bus Interface and Decoder

The MC44011 has a write address of \$8A, and a flag read address of \$8B. It requires that an external microprocessor read the internal flags, and then set the appropriate registers. The MC44011 does not do any automatic internal switching when applied video signals are changed. A block diagram of

the I²C interface is shown in Figure 41. Since writing to the MC44011's registers can momentarily create jitter and other undesirable artifacts on the screen, writing should be done only during vertical retrace (before line 20). Reading of flags, however, can be done anytime.

MC44011

Write to Control Registers

Writing should be done only during vertical retrace. A write cycle consists of three bytes (with three acknowledge bits):

1. The first byte is always the write address for the MC44011 (\$8A).
2. The second byte defines the sub-address register (within the MC44011) to be operated on (\$77 through \$88, and \$00).
3. The third byte is the data for that register.

Communication begins when a start bit (data taken low while clock is high), initiated by the master, is detected, generating an internal reset. The first byte is then entered, and if the address is correct (\$8A), an acknowledge is

generated by the MC44011, which tells the master to continue the communication. The second byte is then entered, followed by an acknowledge. The third byte is the operative data which is directed to the designated register, followed by a third acknowledge.

Sub-Address Registers

The sub-addresses of the 19 registers are at \$77 through \$88, and \$00. 14 of the registers use Bits 0-5 to operate DACs which provide the analog adjustments. Most of the other bits are used to set/reset functions, and to select appropriate inputs/outputs. Table 13 indicates the assignments of the registers.

Table 13. Sub-Address Register Assignments

Sub Address								
	7	6	5	4	3	2	1	0
\$77	S-VHS Y	S-VHS C	FSI	L2 GATE	BLCP	L1 GATE	CBI	CAI
\$78	36/38 μ s	Cal Kill	(R-Y)/(B-Y) adjust DAC					
\$79	H1	V1	Subcarrier balance DAC					
\$7A	Xtal	SSD						
\$7B	T1	T2						
\$7C	SSC	SSA						
\$7D	P1	SSB	Blue bias for YUV operation DAC					
\$7E	P3	P2	Red bias for YUV operation DAC					
\$7F	D3	D1	Pixel Clock VCO Gain adjust DAC					
\$80	RGB EN	D2	Blue Contrast trim DAC					
\$81	Y2 EN	Y1 EN	Main Contrast DAC					
\$82	YUV EN	YX EN	Red Contrast trim DAC					
\$83	L2 Gain	L1 Gain	Blue Brightness trim DAC					
\$84	H Switch	525/625	Main Brightness DAC					
\$85	PClk/2	C Sync	Red Brightness trim DAC					
\$86	V _{in} Sync	PLL1 En	Main Saturation DAC (Color Difference section)					
\$87	Y2 Sync	0	(R-Y)/(B-Y) Saturation balance DAC (Decoder section)					
\$88	V2/V1	RGB Sync	Hue DAC					
\$00	Set to \$00 to start Horizontal Loop if \$88-6 = 0							

Table 14 is a brief explanation of the individual control bits. A more detailed explanation of the functions is found in the block diagram description of the text (within the Functional Description section). Table 15 provides an explanation of the

DACs. Each DAC is 6 bits wide, allowing 64 adjustment steps. The proper sequence and control of the bits and DACs, to achieve various system functions, is described in the Applications Information section.

MC44011

Table 14. Control Bit Description

Control Bit	Name	Description
\$77-7	S-VHS-Y	Set to 0 for normal Composite Video inputs at V1 and/or V2 (Pins 1, 3). Set to 1 for S-VHS (YC) operation. When 1, the Y-input at the selected video input (V1 or V2, selected by Bit \$88-7) bypasses the initial luma delay line, and associated luma/chroma filters and peaking. The signal passes through the second luma delay, adjustable with Bits D1-D3. Luma is output at Pin 33.
\$77-6	S-VHS-C	Set to 0 for normal Composite Video inputs at V1 and/or V2 (Pins 1, 3). Set to 1 for S-VHS (YC) operation. When 1, the chroma input at the non-selected video input (V1 or V2 by Bit \$88-7) is directed to the ACC loop and PAL/NTSC detector. Color difference signals are then output at Pins 41 and 42.
\$77-5	FSI	Set to 0 for a Vertical Sync output rate of 50 Hz. Set to 1 for 100 Hz. Useable in PAL systems only.
\$77-4	L2 GATE	When set to 0, the pixel clock charge pump (PLL2) operation is inhibited during the Vertical Retrace to minimize momentary instabilities. When set to 1, PLL2 operation is not inhibited.
\$77-3	BLCP GATE	When 0, Vertical Gating of the black level clamp pulse during the Vertical Retrace occurs to minimize momentary instabilities. The Vertical Gating can be inhibited by setting this bit to 1.
\$77-2	L1 GATE	When set to 0, the horizontal PLL's phase detector (PLL1) operation is inhibited during the Vertical Retrace to minimize momentary instabilities. When set to 1, the phase detector is not inhibited. If PLL1 gain is high (Bit \$83-6 = 1), gating cannot be enabled.
\$77-1, 0	CB1, CA1	Sets the Vertical Timebase operating method according to Table 10.
\$78-7	36/68 μ s	When 0, the time delay from the sync polarity reversal within the Composite Sync to the leading edge of the Vertical Sync output (Pin 4) is 36 μ s. When 1, the time delay is 68 μ s. (See Figure 33 and 34).
\$78-6	CalKill	When 0, the Horizontal Calibration Loop is enabled for two lines (lines 4 and 5) in each field. When 1, the Calibration Loop is not engaged. Upon power-up, this bit is ineffective (Calibration Loop is enabled) until bit \$86-6 is set to 0, and register \$00 is set to \$00.
\$79-7	HI	This bit is not used in the MC44011, and must be set to 1.
\$79-6	VI	This bit is not used in the MC44011, and must be set to 1.
\$7A-7	Xtal	When 0, the crystal at Pin 38 (17.7 MHz) is selected. When 1, the crystal at Pin 36 (14.3 MHz) is selected.
\$7A-6	SSD	This bit is not used in the MC44011, and must be set to 0.
\$7B-7, 6	T1, T2	Used to set the Sound Trap Notch filter frequency according to Table 3.
\$7C-7, 6 \$7D-6	SSC, SSA, SSB	Sets the NTSC/PAL decoder to the correct system according to Table 4.
\$7D-7 \$7E-7, 6	P1, P2, P3	Sets the Luma Peaking in the decoder section according to Table 5. (See text).
\$7F-7, 6 \$80-6	D3, D1, D2	Sets the Luma Delay in the decoder section according to Table 6. (See text).
\$80-7	RGB EN	When 0, permits the RGB inputs (Pins 26 to 28) to be selected with the Fast Commutate (FC) input (Pin 25). When 1, the FC input is disabled, preventing the RGB inputs from being selected. When the RGB inputs are selected, the Color Difference inputs (Pins 30, 31) are deselected.
\$81-7	Y2 EN	When 1, the Y2 Luma input (Pin 29) is selected. When 0, it is deselected.
\$81-6	Y1 EN	When 1, the Y1 Luma Signal (provided by the decoder section to the color difference section) is selected. When 0, it is deselected.
\$82-7	YUV EN	When 0, Pins 20 to 22 provide RGB output signals. When 1, those pins provide YUV output signals.
\$82-6	YX EN	Effective only when the RGB inputs are selected. When 0, the RGB inputs (Pins 26 to 28) are directed to the RGB outputs (Pins 20 to 22) via the Contrast and Brightness controls. When 1, the RGB inputs are directed through the Color Difference Matrix, allowing Saturation control in addition to the Brightness and Contrast controls. See Figure 36.
\$83-7	L2 Gain	When 0, the gain of the pixel clock VCO (PLL2) is high (50 μ A). When 1, the gain is low (20 μ A).
\$83-6	L1 Gain	When 0, the Horizontal Phase Detector Gain (PLL1) is low. When 1, the gain is high.
\$84-7	H Switch	When 0, Pin 12 is open. When 1, Pin 12 is internally switched to ground, allowing the PLL1 filter operation to be adjusted for noisy signals.

MC44011

Table 14. Control Bit Description (continued)

Control Bit	Name	Description
\$84-6	525/625	This bit sets the division ratio from the crystal for the reference frequency for the Horizontal Calibration Loop. For NTSC systems, set to 1. For PAL systems, set to 0.
\$85-7	PClk/2	When 0, the PLL2 VCO provides the Pixel Clock at Pin 18 directly. When 1, the VCO output is directed through a + 2 stage, and then to Pin 18.
\$85-6	C Sync	When 0, Pin 13 will provide a square wave of ≈ 250 kHz ($16 \times F_h$). When 1, Pin 13 provides a negative composite sync signal. See Figures 25, 27, 30, 31.
\$86-7	V _{in} Sync	When 1, Composite Sync at the selected Video input (Pin 1 or 3) is used for all internal timing. When 0, the Sync source is selected by Bits \$87-7 and \$88-6. See Table 12.
\$86-6	PLL1 Enable	After power up, this bit must be set to 0, and then register \$00 set to \$00, to enable the Horizontal Loop (PLL1). Setting this bit to a 1 will disable the Horizontal Loop, and engages the Calibration Loop.
\$87-7	Y2 Sync	When 1, and \$86-7 = \$88-6 = 0, Composite Sync at the Y2 input (Pin 29) is used for all internal timing. When 0, the Sync source is selected by Bits \$86-7 or \$88-6. See Table 12.
\$87-6	0	This bit must always be set to 0.
\$88-7	V2/V1	When Composite Video is applied, and this bit is 0, the Video 2 input (Pin 3) is directed to the Sound Trap. When 1, the Video 1 input (Pin 1) is selected. In S-VHS applications, when 0, Pin 3 is the Y (luma) input, and Pin 1 is the chroma input. When this bit is 1, Pin 1 is the luma input, and Pin 3 is the chroma input.
\$88-6	RGB Sync	When 1, and \$86-7 = \$87-7 = 0, Composite Sync at any or all of the RGB inputs (Pin 26 to 28) is used for all internal timing. When 0, the sync source is selected by Bits \$86-7 or \$87-7. See Table 12.

Table 15. Control DAC Description

Control Bits	Description
\$78-5/0	This DAC allows for a relative gain adjustment of the R-Y and B-Y outputs (Pins 41, 42) as a means of adjusting the color decoding accuracy. Nominal setting is 32.
\$79-5/0	Used to balance out reference errors of the color subcarrier, primarily for NTSC. Nominal setting is 32. Adjustment range is $\approx \pm 5^\circ$.
\$7D-5/0	Used to set the U (Pin 22) DC bias level. When in the YUV mode (\$82-7 = 1), this setting should nominally be 32. When in RGB mode, set to 00.
\$7E-5/0	Used to set the V (Pin 22) DC bias level. When in the YUV mode (\$82-7 = 1), this setting should nominally be 32. When in RGB mode, set to 00.
\$7F-5/0	Used to fine tune the gain of the Pixel Clock VCO to obtain optimum performance without instabilities. A setting of 63 will shut off the VCO. Setting 50 to 62 provide non-square wave outputs, and can be unstable. As the setting is increased from 00 to 49, the gain is increased. Changing this register does not change the Pixel Clock frequency.
\$80-5/0	Used to fine tune the contrast of the Blue output when in RGB mode. In YUV mode this provides a fine tuning of the color, similar to, but not to be confused with, hue.
\$81-5/0	Used to adjust the gain of the three outputs. In RGB mode this is the Contrast control.
\$82-5/0	Used to fine tune the contrast of the Red output when in RGB mode. In YUV mode this provides a fine tuning of the color, similar to, but not to be confused with, hue.
\$83-5/0	Used to fine tune the brightness of the Blue output when in RGB mode. In YUV mode this provides a fine tuning of the color, similar to, but not to be confused with, hue.
\$84-5/0	Used to adjust the brightness of the three RGB outputs. In YUV mode this DAC affects only Y output (Pin 21).
\$85-5/0	Used to fine tune the brightness of the Red output when in RGB mode. In YUV mode this provides a fine tuning of the color, similar to, but not to be confused with, hue.
\$86-5/0	Used to adjust the saturation of the RGB/YUV outputs of the Color Difference section.
\$87-5/0	Used to adjust the saturation of the R-Y, B-Y outputs (Pins 41, 42) of the Decoder section.
\$88-5/0	Used to adjust the hue of the R-Y, B-Y outputs (Pins 41, 42). Nominal setting is 32.
\$00-7/0	This register must be set to 00, after Bit \$86-6 is set to 0, to enable the Horizontal Loop (PLL1) after power up, or anytime when Bit \$86-6 is set to 0 after having been a 1.

The above DACs are 6-bits wide. The settings mentioned above, and in subsequent paragraphs are given in decimal values of 00 to 63. These are not hex values.

MC44011

Reading Flags

A read cycle need not be restricted to the vertical interval, but may be done anytime. A flag read cycle consists of three bytes (with three acknowledge bits):

- The first byte is always the Read address for the MC44011 (\$8B).
- The second and third bytes are the flag data.

Communication begins when a start bit (data taken low while clock is high), initiated by the master (not the MC44011), is detected, generating an internal reset. The first byte (address) is then entered, and if correct, an acknowledge is

generated by the MC44011. The flag bits will then exit the MC44011 as two 8 bit bytes at clock cycles 10-17 and 19-26. The master (receiving the data) is expected to generate the acknowledge bits at clocks 18 and 27. The master must then generate the stop bit.

The MC44011 flags must be read on a regular basis to determine the status of the various circuit blocks. The MC44011 does not generate interrupts. It is recommended the flags be read once per field or frame. See Table 16 for a description of the flags.

Table 16. Flag Description

Clock No.	Description (When Flag = 1)
10	Internally set to a Logic 1.
11	Horizontal Loop (PLL1) enabled, indicating the loop can be driven by the incoming sync. This bit will be low upon power up, and will change to a 1 after initialization of control Bit \$86-6 and register \$00.
12	Horizontal Loop (PLL1) not locked. Lack of incoming sync, or wrong sync source selection, or the wrong horizontal frequency, will cause the Coincidence Detector to indicate a "not locked" condition.
13	Internally set to Logic 0.
14	Less than 576 horizontal lines counted per frame. This flag helps determine the applied video system. When high, a 525 line system (NTSC) is indicated. When low, a 625 line system (PAL) is indicated.
15	Vertical Countdown engaged. When high, this flag indicates the Vertical Countdown section has successfully maintained lock for 8 consecutive fields, indicating therefor a successful vertical lock-up. This flag is low in the Injection Lock mode.
16	Internally set to a Logic 1.
17	Internally set to a Logic 1.
18	(Acknowledge pulse).
19	Pixel clock VCO control voltage too low (< 1.7 V at Pin 16). This indicates the VCO may not function correctly as the control voltage is near one end of its range. The DAC setting at register \$7F-5/0 must be increased, and/or the + 2 block must be selected (set \$85-7 = 1), to clear this flag.
20	Pixel clock VCO control voltage too high (> 3.3 V at Pin 16). This indicates the VCO may not function correctly as the control voltage is near one end of its range. The DAC setting at register \$7F-5/0 must be reduced, and/or the + 2 block must be deselected (set \$85-7 = 0) to clear this flag. This flag will be high if the VCO is off (DAC \$7F = 63).
21	Internally set to a Logic 1.
22	Internally set to a Logic 0.
23	ACC Loop is active, indicating it is locked up to the color burst signal. The Color Burst amplitude must exceed 30 mV _{p-p} , and the correct crystal selected, for lock-up to occur.
24	PAL system identified by the decoder, indicating the decoder recognizes the line-by-line change in the burst phase. When NTSC is applied, this flag is 0.
25	Not used.
26	Internally set to a Logic 0.
27	(Acknowledge pulse).

MC44011

APPLICATIONS INFORMATION

Design Procedure and PC Board Layout

The external components required by the MC44011 are shown in Figure 42. Except for the crystals, all the components are standard value resistors and capacitors, and

can be non-precision. Table 17 describes the external components for each pin.

Figure 42. Basic Functional Circuit

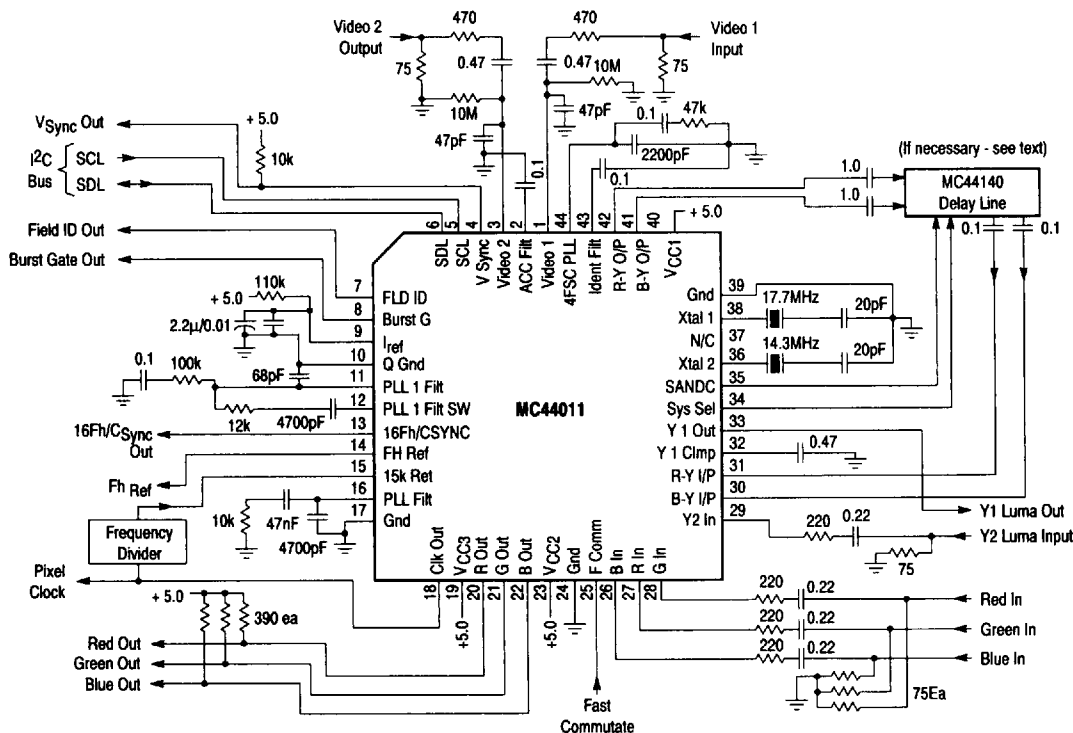

Crystal Specifications and Operation

The crystals used with the MC44011 should comply with Table 18 specifications.

Table 18. Crystal Specifications

Frequency: (4 x Subcarrier)	NTSC (14.31818 MHz) PAL (17.734472 MHz) PAL-M (14.30244 MHz)
Pull-in range:	± 1600 Hz (with respect to crystal frequency)
Tolerance:	30 ppm (with fixed load capacitor)
Temperature Coefficient:	50 ppm (with fixed load capacitor)
Operating Mode:	Fundamental series resonance
Load Capacitance:	Nominally 20 pF
Motional Capacitance:	10 to 30 fF
Series Resistance:	< 30 Ω (nominally 10 Ω)

The oscillator output resistance at Pin 36 is nominally 300 Ω for NTSC mode, and 400 Ω at Pin 38 for PAL mode. It is recommended that a stray capacitance (PC board, package pins, etc.) of 4.0 to 5.0 pF be included when selecting a crystal.

The above values for tolerance and temperature coefficient can be increased if a trimmer capacitor is used for the load capacitor.

The crystal PLL filter (Pin 44) voltage is between 1.8 and 3.8 V in normal operation. If the color output of the MC44011 is incorrect, or non-existent (ACC flag off), this voltage should be checked. If it is beyond either of the above limits, the capacitor in series with the crystal should be changed so as to allow the PLL to pull-in the crystal. The capacitor is generally specified by the crystal manufacturer, but should also comply with Table 18 specifications. If no burst is present, Pin 44 voltage will be ≈ 1.3 V.

The selected crystal frequency can be checked by using a scope at the non-selected crystal pin. The signal amplitude is nominally 200 to 400 mVp-p. In this way the selected crystal's frequency is not affected by the scope probe.

MC44011

Table 17. External Components

Pin No.	Name	Function
1, 3	Video 1, Video 2	Input signals must be capacitor-coupled. The 470 Ω resistors protect the pins from ESD and RFI. The 75 Ω resistors are not required by the MC44011, but depend on the signal source. The 47 pF capacitors filter high frequency noise.
2	ACC Filter	The 0.1 μ F ceramic capacitor filters the Automatic Gain circuit.
4	Vert. Sync	The pull-up resistor is required for this open-collector output.
5, 6	SCL, SDL	Pull-up resistors are required on each I ² C line since outputs are open-collector. They are typically located at the master device.
7	Field ID	No external components required.
8	Burst Gate	No external components required.
9	I _{ref}	The 110 k Ω resistor provides \approx 32 μ A from the + 5.0 V source. This pin must be well filtered to the Quiet Ground (Pin 10).
10	Quiet GND	This is the Reference Ground for Pin 9 and the PLL1 Filter.
11	PLL1 Filter	The 100 k Ω resistor, and the 0.1 μ F and 68 pF capacitors are the filter network for this PLL. Connect to Pin 10 ground.
12	PLL1 Filt. SW	The 12 k Ω resistor and 470 pF capacitor give the filter a longer time constant when Pin 12 is switched in.
13	16 Fh/C _{Sync}	No external components required.
14	Fh Ref	No external components required.
15	15 k Return	TTL Return signal from external frequency divider.
16	PLL2 Filter	The 10 k Ω resistor and 47 nF and 4.7 nF capacitors are the filter network for this PLL. Connect to Pin 17 ground.
17	Ground	Ground for the Pixel Clock circuit.
18	Clk Out	Pixel Clock output to external frequency divider and triple A/D converter.
19	V _{CC3}	+ 5.0 V supply for the Pixel Clock circuit.
20, 21, 22	R, G, B Out	The 390 Ω pull-up resistors are required for these open-collector outputs. The pull-ups should go to a clean, well filtered + 5.0 V supply. These pins cannot drive 75 Ω directly. If required to do so, see text for suggested buffer.
23	V _{CC2}	+ 5.0 V supply for the Color Difference section.
24	Ground	Ground for the Color Difference section.
25	Fast Comm.	No external components required. This input <i>should not</i> be left open.
26, 27, 28	B, G, R In	Input signals must be capacitor-coupled. The 220 Ω resistors protect the pins from ESD and RFI.
29	Y2 Input	Input signals must be capacitor-coupled. The 220 Ω resistor protects the pin from ESD and RFI. The 75 Ω resistor is not required by the MC44011, but depends on the signal source.
30, 31	B-Y, R-Y In	Input signals must be capacitor-coupled. The MC44140 is required if PAL signals are processed (see text).
32	Y1 Clamp	The 0.1 μ F ceramic capacitor provides clamping for the Y1 output.
33	Y1 Out	No external components required. This pin cannot drive 75 Ω directly. If required to do so, see text for suggested buffer.
34, 35	System Sel., Sandcastle	For use by the MC44140 delay line. No other external components required.
36, 38	Xtal 2, Xtal 1	A 17.7 MHz crystal is required (at Pin 38) for PAL signals, and a 14.3 MHz crystal is required (at Pin 36) for NTSC signals. If only one crystal is required, leave the other pin open. The series capacitor depends on the crystal manufacturer. (See Table 18 for crystal specs.)
37	N/C	No external components required.
39	Ground	Ground for Color Decoder section.
40	V _{CC1}	+ 5.0 V supply for the Color Decoder section.
41, 42	B-Y, R-Y Out	The MC44140 is required if PAL signals are processed. Otherwise, capacitor-couple to Pins 30, 31 (see text).
43	Ident. Filter	The 0.1 μ F ceramic capacitor provides filtering for the Identification circuit.
44	4FSC PLL	The 47 k Ω resistor, and 0.1 μ F and 2.2 nF capacitors are the filter network for the crystal PLL. Connect to Pin 39 ground.

MC44011

Power Supplies and Ground

There are three V_{CC} pins (Pins 19, 23, and 40) which must be connected to a source of +5.0 V, $\pm 5\%$. Since the three pins are internally connected by diodes, none can be left open, even if a particular section (such as the Pixel Clock Generator) is to be unused. Total current required is ≈ 135 mA (including the RGB output load current). There are four ground pins (Pins 10, 17, 24, and 39) which must be connected together, and preferably connected to a ground plane.

Pins 19 and 17 are the V_{CC} and ground for the Pixel Clock Generator, and the circuitry associated with the Pixel Clock should be referenced to those two pins.

Pins 23 and 24 are the V_{CC} and ground for the Color Difference section, which includes the RGB outputs. The output pull-up resistors should be connected to the V_{CC} at Pin 23.

Pins 40 and 39 are the V_{CC} and ground for the Color Decoder, Sync Separator, Horizontal PLL and the Vertical Decoder. Pin 10 is the Quiet Ground for the horizontal PLL's VCO and filter, and therefore, the components on Pins 9 and 11 should be connected as close as possible to Pin 10.

Bypassing of the power supplies must be done as close as possible to each V_{CC} pin, and at the output pull-up resistors. Recommended bypassing components are a 10 μ F tantalum capacitor in parallel with a 0.01 μ F ceramic.

Input Signals

The various video inputs, Video 1 and 2, Red In, Green In, Blue In, R-Y, B-Y, and Y2 inputs, are designed to accept standard level analog video waveforms. They are not designed for digital signals. The input impedance of the above pins is high. The need for 75 Ω terminations for those video signals depends on the video source itself. All of the above signals must be capacitor-coupled as clamping is provided internally.

The I²C inputs (SCL, SDL) are designed according to the I²C specifications, which define V_{OL} as between 0 and 1.5 V, and V_{OH} as between 3.0 V to V_{CC} . See Appendix C.

The 15 k Return and Fast Commutate (Pins 15 and 25, respectively) are designed for TTL level signals. If unused, they should not be left open, but connected to +5.0 V, or ground, as appropriate.

Output Signals

The RGB/YUV outputs are open-collector, and require pull-up resistors (typically 390 Ω) to a clean +5.0 V (V_{CC2}). The output impedance is such that the load impedance (to ground) should be >1.5 k Ω . If it is desired to drive a 75 Ω load (e.g., a monitor) from these outputs, a simple buffer (see Figure 43) can be added.

Figure 43. Output Buffer

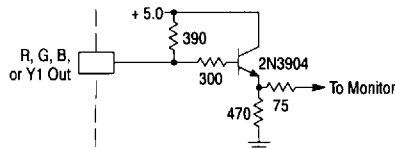

The Y1 output (Pin 33) has an output impedance of ≈ 300 Ω , and can be used as a monitoring point, or to drive the input of the MC44145 sync separator, or other high impedance loads (minimum load for Y1 is 1.0 k Ω). If it is to be used to drive a 75 Ω load, the buffer shown in Figure 43 can be used, *except the 390 Ω resistor must be deleted*.

The Vertical Sync output (Pin 4) is an open-collector logic level output, and requires a pull-up resistor to +5.0 V. 10 k Ω is recommended, but it can be as low as 1.0 k Ω . The I²C data line (SDL, Pin 6) is also open-collector when it is an output, and can sink a maximum of 3.0 mA. Only one pull-up resistor is required on the SDL line (regardless of the number of devices on that line), and it is typically near the master device. The Field ID, Burst Gate, 16 Fh/CSync, Fh Ref, and Pixel Clock outputs are logic level totem-pole outputs.

PC Board

The PC board layout should be neat and compact, and should preferably have a ground plane. If feasible, a second plane should be provided for the +5.0 V supply, but this is not mandatory. The components at Pins 9 and 11 should be connected to the same ground track which goes to Pin 10. The V_{CC} and ground should be connected as directly as possible to the power supply, and not routed through a maze of digital circuitry before arriving at the MC44011. Since the MC44011 is intended to be used with A/D converters and high speed digital signals, it is expected digital circuitry will be on the same board. Care should be taken in the layout to prevent digital noise from entering the analog portions of the MC44011. The most sensitive pins are Pins 1, 2, 3, 9, 10, 11, 12, 16, and 44, and should be protected from noise.

Initialization and Programming Information

Upon powering up the MC44011, initialization consists of first filling the registers with initial values to set a known condition. Table 19 provides recommended values for the initial settings, although these may be tailored for each application (with the exception of Bits \$79-6, 7, \$7A-6, \$86-6, and \$87-6). Table 19 settings will set up the MC44011 to the following conditions:

- Composite video input at Video 1 (Pin 1), NTSC, using the crystal at Xtal 2 (Pin 36).
- Y1 enabled, RG outputs enabled, and Composite Sync at Pin 13
- RGB inputs not enabled (R-Y, B-Y inputs are enabled)
- The Sound Trap at 4.5 MHz
- The Luma Peaking at 0 dB
- The Luma Delay at minimum
- High gain and high noise rejection for the horizontal PLL
- Vertical decoder set to Injection Lock mode
- The Pixel Clock VCO is off

After the registers are initialized, then set Bit \$86-6 to 0, and load register \$00 with \$00. This will enable the horizontal PLL, permitting normal operation.

MC44011

Table 19. Recommended Initial Settings

Sub Address	7	6	5	4	3	2	1	0
\$77	S-VHS Y = 0	S-VHS C = 0	FSI = 0	L2 Gain = 0	BLCP = 0	L1 Gain = 0	CBI = 0	CAI = 1
\$78	36/68 μ s = 0	Calkill = 0	(R-Y)/(B-Y) Adjust DAC = 32					
\$79	HI = 1	VI = 1	Subcarrier Balance DAC = 32					
\$7A	Xtal = 1	SSD = 0						
\$7B	T1 = 1	T2 = 1						
\$7C	SSC = 0	SSA = 1						
\$7D	P1 = 1	SSB = 0	Blue Bias = 00					
\$7E	P3 = 1	P2 = 1	Red Bias = 00					
\$7F	D3 = 0	D1 = 0	Pixel Clock VCO Gain Adjust = 63					
\$80	RGB EN = 1	D2 = 0	Blue Contrast Trim = 32					
\$81	Y2 EN = 0	Y1 EN = 1	Main Contrast = 47					
\$82	YUV EN = 0	YX EN = 0	Red Contrast Trim = 32					
\$83	L2 Gain = 1	L1 Gain = 1	Blue Brightness Trim = 32					
\$84	H Switch = 1	525/625 = 1	Main Brightness = 30					
\$85	PClk/2 = 1	C _{Sync} = 1	Red Brightness Trim = 32					
\$86	V _{in} Sync = 1	PLL1 EN = 1	Main Saturation (Color Difference section) = 32					
\$87	Y2 Sync = 0	0	(R-Y)/(B-Y) Saturation Balance (Decoder section) = 15					
\$88	V2/V1 = 1	RGB _{Sync} = 0	Hue = 32					

These settings are for power-up initialization only. Refer to the text, and Appendix B, for subsequent modifications based on the application.

Then, after selecting the desired input(s) (from Pins 1, 3, or 26 to 31), and based on the applied signals at those inputs, and by reading the flags, the registers are adjusted for the desired and proper mode of operation. A suggested routine for setting modes is given in Appendix B. The "initial values" in the Control DACs table of Appendix B are those in Table 19. The remainder of the flow chart is a recommendation only, and should be tailored for each application.

The monitoring of flags should be done on a regular basis, and it is recommended it be done once per field. See Table 16 (in the Functional Description section) for a summary of the flags. Should any flags change, the following procedures are recommended:

Flag 11 (Horizontal Enabled) – Once enabled by setting Bit \$86-6 = 0, this flag should always remain a 1. Should it change to 0, reset \$86-6 to 0, and write \$00 to register \$00 again. If the flag does not return to a 1, this indicates a possible device malfunction.

Flag 12 (Horizontal Out-of-Lock) – When 1, this indicates:

- the wrong input is selected (Bits \$88-7, \$81-7, \$80-7, and \$77-7,6), or;
- the wrong sync source is selected (Bits \$86-7, \$87-7, and \$88-6), or;
- the incoming signal is somewhat unstable, as from a VCR tape (change Bit \$83-6), and/or;
- the incoming signal is noisy (change Bit \$84-7), or;
- a loss of the incoming signal with sync.

(It is possible for this flag to flicker when the video signal is from a poor quality tape, or other poor quality source.)

Flag 14 (Less than 576 lines) – This flag, from the vertical decoder, is used to help determine if the signal is PAL or NTSC. Should it change, this indicates the incoming signal has changed format, or possibly one of the items listed under Flag 12 above.

Flag 15 (Vertical Countdown Engaged) – Bits 77-0 and 1 must be set to 1 (after Flag 12 reads 0) for this flag to indicate correctly. Then this flag will change to a 1 after 8 fields of successful synchronization of the internal counters with the incoming signal. To change to a 0 requires 8 consecutive fields of non-synchronization. If this flag changes to 0, this indicates a loss of signal, a change of signal format, or instability in the horizontal PLL.

Flags 19, 20 (VCO Control Voltage Low/High) – These flags are meaningful only if the Pixel Clock Generator is used. If Flag 19 is a 1, the gain of the pixel clock VCO needs to be increased by increasing the value of register \$7F, and/or set Bit \$85-7 = 1. If Flag 20 is a 1, the value of the register must be decreased, and/or set Bit \$85-7 = 0. If the VCO is turned off (\$7F = 63), Flag 19 will be 0, and Flag 20 will be 1.

Flag 23 (ACC Active) – If this flag is a 0, it indicates the ACC loop is not active. This will happen if the burst signal is less than 30 mVp-p, if the incorrect crystal is selected (\$7A-7), if the crystal PLL is not locked, or if the horizontal PLL is not locked.

Flag 24 (PAL Identified) – This flag is a 1 when PAL signals are applied, and a 0 when NTSC signals are applied, or when no burst is present.

It is recommended that the Color Decoder section, and crystal, should be set according to the state of Flags 14, 23, and 24 according to Table 20.

MC44011

Figure 45. Typical Waveforms

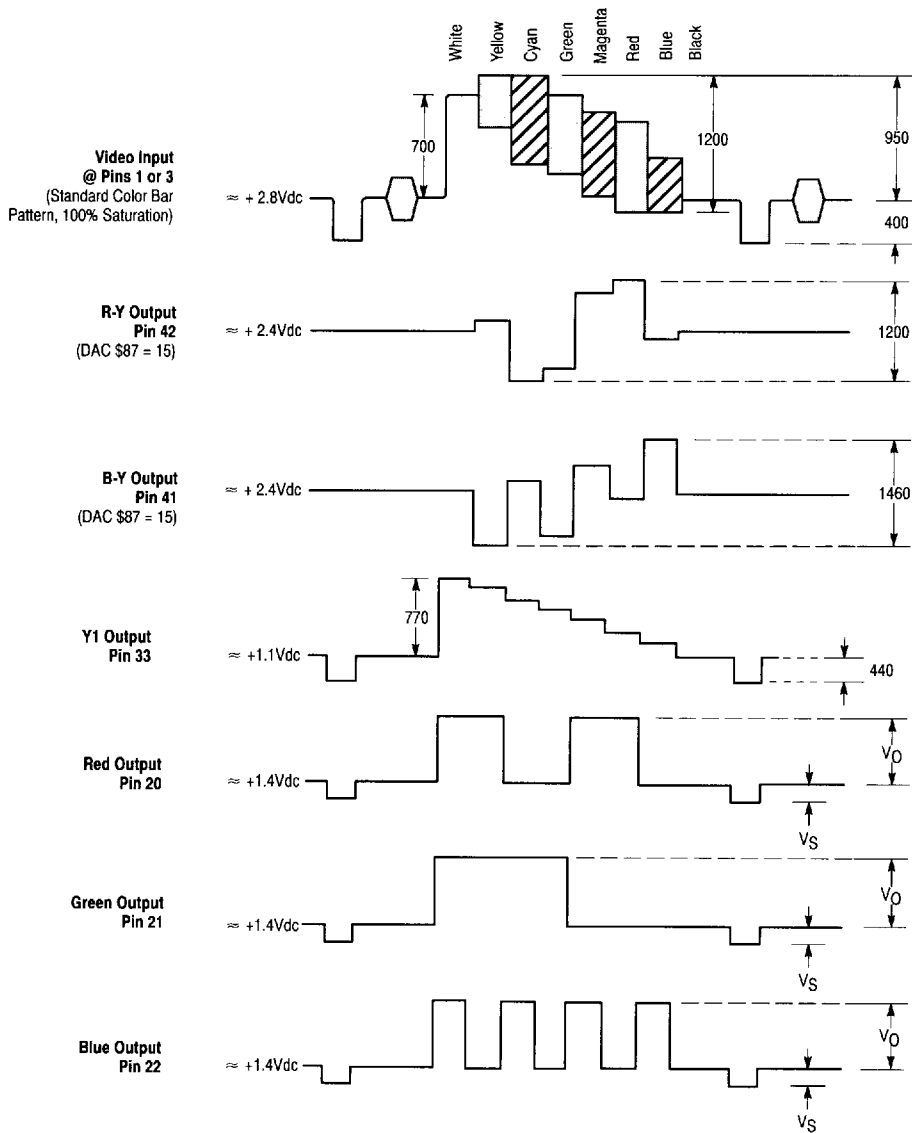

DACs set per Table 19. All amplitudes in millivolts.
 Voltages are nominal, and do not represent guaranteed limits.

DAC 81	V _O	V _S
32	1725	220
47	2360	340
63	3160	440

MC44011

Connecting the MC44011 to the MC44250 or MC44251 A/D Converter

The MC44250 and MC44251 triple A/D converters are designed to accept RGB or YUV inputs, and provide 8-bit equivalents of each. Additionally, the inputs have black level clamps, allowing the input signals to be capacitor-coupled. The simplified schematic of Figure 47 shows the connections

between the MC44011 and the MC44250/1, including anti-aliasing filters between the devices. Connection to other A/D converters would be done in a similar manner. Refer to the appropriate data sheet for details.

Figure 47. Connecting to a Triple A/D Converter

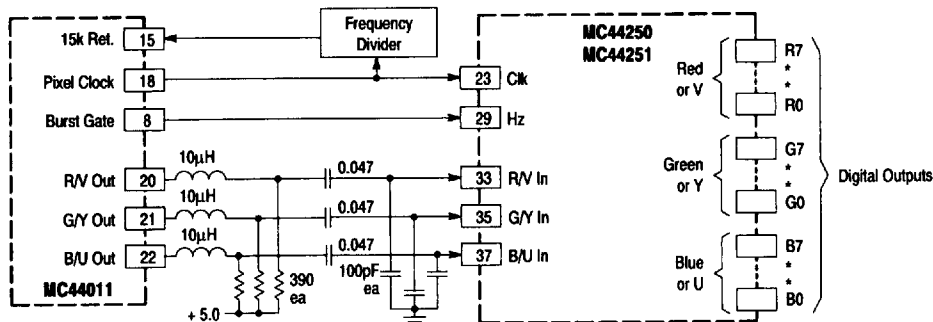

Connecting the MC44011 to the MC141621 or MC141625 NTSC Comb Filter

A comb filter can be used ahead of the MC44011 to enhance picture quality by providing a more accurate separation of the luma and chroma components from the composite video, without sacrificing bandwidth. The usual benefits are reduced dot crawl, and increased color purity. Figure 48 (a simplified schematic) shows the normal mode of

implementing the MC141621 (NTSC) or MC141625 (PAL/NTSC) comb filter with the MC44011. The two comb filters can also provide the Y and C signals in digital format. Refer to their data sheets for details. The MC14576A op amps have an internally set gain of 2.

Figure 48. Implementing the Comb Filter

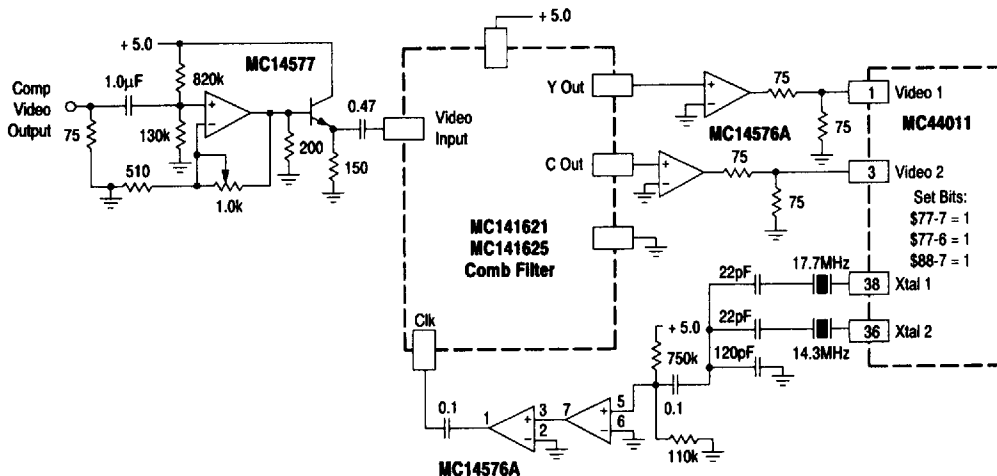

MC44011

APPENDIX A

Control Bit Summary

Bit 7	6	5	4	3	2	1	0																																																		
\$77	S-VHS Y	S-VHS C	FSI	L2 Gate	BLCP	L1 Gate	CBI CAI																																																		
	0 = Comp. Video 1 = S-VHS		0 = 50 Hz 1 = 100 Hz	0 = PLL2 Gating	0 = Clamp Gating	0 = PLL1 Gating	<table border="1"> <tr> <th>CBI</th> <th>CAI</th> <th>Sync Mode</th> </tr> <tr> <td>0</td> <td>0</td> <td>Force 625</td> </tr> <tr> <td>1</td> <td>0</td> <td>Force 525</td> </tr> <tr> <td>0</td> <td>1</td> <td>Inj. Lock</td> </tr> <tr> <td>1</td> <td>1</td> <td>Auto Count</td> </tr> </table>	CBI	CAI	Sync Mode	0	0	Force 625	1	0	Force 525	0	1	Inj. Lock	1	1	Auto Count																																			
CBI	CAI	Sync Mode																																																							
0	0	Force 625																																																							
1	0	Force 525																																																							
0	1	Inj. Lock																																																							
1	1	Auto Count																																																							
\$78	36/68	CalKill	Vertical Time Constant 1 = Cal Loop Disabled																																																						
\$79	HI	V1	Set to 1, 1																																																						
\$7A	Xtal	SSD	Set to 0 1 = Pin 36 Crystal																																																						
\$7B	T1	T2	<table border="1"> <tr> <th colspan="4">Sound Trap Notch Frequency</th> </tr> <tr> <th>T1</th> <th>T2</th> <th>PAL</th> <th>NTSC</th> </tr> <tr> <td>0</td> <td>0</td> <td>6.5 MHz</td> <td>5.25 MHz</td> </tr> <tr> <td>0</td> <td>1</td> <td>5.5 + 5.75 MHz</td> <td>4.44 + 4.64 MHz</td> </tr> <tr> <td>1</td> <td>0</td> <td>6.0 MHz</td> <td>4.84 MHz</td> </tr> <tr> <td>1</td> <td>1</td> <td>5.5 MHz</td> <td>4.44 MHz</td> </tr> </table>					Sound Trap Notch Frequency				T1	T2	PAL	NTSC	0	0	6.5 MHz	5.25 MHz	0	1	5.5 + 5.75 MHz	4.44 + 4.64 MHz	1	0	6.0 MHz	4.84 MHz	1	1	5.5 MHz	4.44 MHz																										
Sound Trap Notch Frequency																																																									
T1	T2	PAL	NTSC																																																						
0	0	6.5 MHz	5.25 MHz																																																						
0	1	5.5 + 5.75 MHz	4.44 + 4.64 MHz																																																						
1	0	6.0 MHz	4.84 MHz																																																						
1	1	5.5 MHz	4.44 MHz																																																						
\$7C	SSC	SSA	<table border="1"> <tr> <th>SSA</th> <th>SSB</th> <th>SSC</th> <th>Color System</th> </tr> <tr> <td>0</td> <td>0</td> <td>0</td> <td>Not Used</td> </tr> <tr> <td>0</td> <td>1</td> <td>0</td> <td>PAL</td> </tr> <tr> <td>1</td> <td>0</td> <td>0</td> <td>NTSC</td> </tr> <tr> <td>0</td> <td>1</td> <td>1</td> <td>Color Kill</td> </tr> <tr> <td>X</td> <td>X</td> <td>1</td> <td>External</td> </tr> </table>					SSA	SSB	SSC	Color System	0	0	0	Not Used	0	1	0	PAL	1	0	0	NTSC	0	1	1	Color Kill	X	X	1	External																										
SSA	SSB	SSC	Color System																																																						
0	0	0	Not Used																																																						
0	1	0	PAL																																																						
1	0	0	NTSC																																																						
0	1	1	Color Kill																																																						
X	X	1	External																																																						
\$7D	P1	SSB	<table border="1"> <tr> <th>P1</th> <th>P2</th> <th>P3</th> <th>Y1 Peak</th> </tr> <tr> <td>0</td> <td>0</td> <td>0</td> <td>9.5 dB</td> </tr> <tr> <td>0</td> <td>0</td> <td>1</td> <td>8.5</td> </tr> <tr> <td>1</td> <td>0</td> <td>0</td> <td>7.7</td> </tr> <tr> <td>1</td> <td>0</td> <td>1</td> <td>6.5</td> </tr> <tr> <td>0</td> <td>1</td> <td>0</td> <td>5.3</td> </tr> <tr> <td>0</td> <td>1</td> <td>1</td> <td>3.8</td> </tr> <tr> <td>1</td> <td>1</td> <td>0</td> <td>2.2</td> </tr> <tr> <td>1</td> <td>1</td> <td>1</td> <td>0</td> </tr> </table>					P1	P2	P3	Y1 Peak	0	0	0	9.5 dB	0	0	1	8.5	1	0	0	7.7	1	0	1	6.5	0	1	0	5.3	0	1	1	3.8	1	1	0	2.2	1	1	1	0														
P1	P2	P3	Y1 Peak																																																						
0	0	0	9.5 dB																																																						
0	0	1	8.5																																																						
1	0	0	7.7																																																						
1	0	1	6.5																																																						
0	1	0	5.3																																																						
0	1	1	3.8																																																						
1	1	0	2.2																																																						
1	1	1	0																																																						
\$7E	P3	P2	<table border="1"> <tr> <th>D1</th> <th>D2</th> <th>D3</th> <th colspan="2">Luma Delay</th> </tr> <tr> <td>0</td> <td>0</td> <td>0</td> <td>14.3 MHz</td> <td>17.7 MHz</td> </tr> <tr> <td>0</td> <td>0</td> <td>1</td> <td>690 ns</td> <td>594 ns</td> </tr> <tr> <td>0</td> <td>1</td> <td>0</td> <td>760</td> <td>650</td> </tr> <tr> <td>0</td> <td>1</td> <td>1</td> <td>830</td> <td>707</td> </tr> <tr> <td>1</td> <td>0</td> <td>0</td> <td>900</td> <td>763</td> </tr> <tr> <td>1</td> <td>0</td> <td>1</td> <td>970</td> <td>819</td> </tr> <tr> <td>1</td> <td>1</td> <td>0</td> <td>1040</td> <td>876</td> </tr> <tr> <td>1</td> <td>1</td> <td>1</td> <td>970</td> <td>819</td> </tr> <tr> <td>1</td> <td>1</td> <td>1</td> <td>1040</td> <td>876</td> </tr> </table>					D1	D2	D3	Luma Delay		0	0	0	14.3 MHz	17.7 MHz	0	0	1	690 ns	594 ns	0	1	0	760	650	0	1	1	830	707	1	0	0	900	763	1	0	1	970	819	1	1	0	1040	876	1	1	1	970	819	1	1	1	1040	876
D1	D2	D3	Luma Delay																																																						
0	0	0	14.3 MHz	17.7 MHz																																																					
0	0	1	690 ns	594 ns																																																					
0	1	0	760	650																																																					
0	1	1	830	707																																																					
1	0	0	900	763																																																					
1	0	1	970	819																																																					
1	1	0	1040	876																																																					
1	1	1	970	819																																																					
1	1	1	1040	876																																																					
\$7F	D3	D1	0 = RGB Inputs Enabled																																																						
\$80	RGB EN	D2	1 = Y1 Enabled 1 = Y2 Enabled 1 = RGB Matrix Enabled 1 = YUV Outputs																																																						
\$81	Y2 EN	Y1 EN	1 = PLL1 Gain High 1 = PLL2 Gain Low																																																						
\$82	YUV EN	YX EN	1 = NTSC 1 = Switch Closed																																																						
\$83	L2 Gain	L1 Gain	1 = Comp. Sync 1 = +2 Enabled																																																						
\$84	H Switch	525/625	0 = PLL1 Enabled 1 = Comp. Video Sync Source																																																						
\$85	PCik/2	C Sync	1 = Comp. Video Sync Source 1 = Y2 Sync Source																																																						
\$86	V _{in} Sync	PLL1 EN	Set to 0 1 = Y2 Sync Source																																																						
\$87	Y2 Sync	0	1 = RGB Sync Source 1 = Pin 1 Input																																																						
\$88	V2/V1	RGB Sync																																																							

9

Control DACs

\$78	R-Y/B-Y Gain Adjustment	\$82	Red Contrast Trim
\$79	Subcarrier Phase	\$83	Blue Brightness Trim
\$7D	Blue DC Bias	\$84	Main Brightness
\$7E	Red DC Bias	\$85	Red Brightness Trim
\$7F	Pixel Clock VCO Gain	\$86	Saturation (Color Diff. Section)
\$80	Blue Contrast Trim	\$87	Saturation (Decoder)
\$81	Main Contrast	\$88	Hue

Flags

10	Internally Set to 1	19	Pixel Clock VCO Gain too low
11	Horizontal Loop (PLL1) Enabled	20	Pixel Clock VCO Gain too high
12	Horizontal Loop not Locked	21	Internally Set to 1
13	Internally Set to 0	22	Internally Set to 0
14	Less than 576 Lines	23	ACC Loop Active
15	Vertical Decoder Engaged	24	PAL Signals Detected
16	Internally Set to 1	25	Not Used
17	Internally Set to 1	26	Internally Set to 0

MC44011

APPENDIX B

Suggested Mode Setting Routine (Simplified)

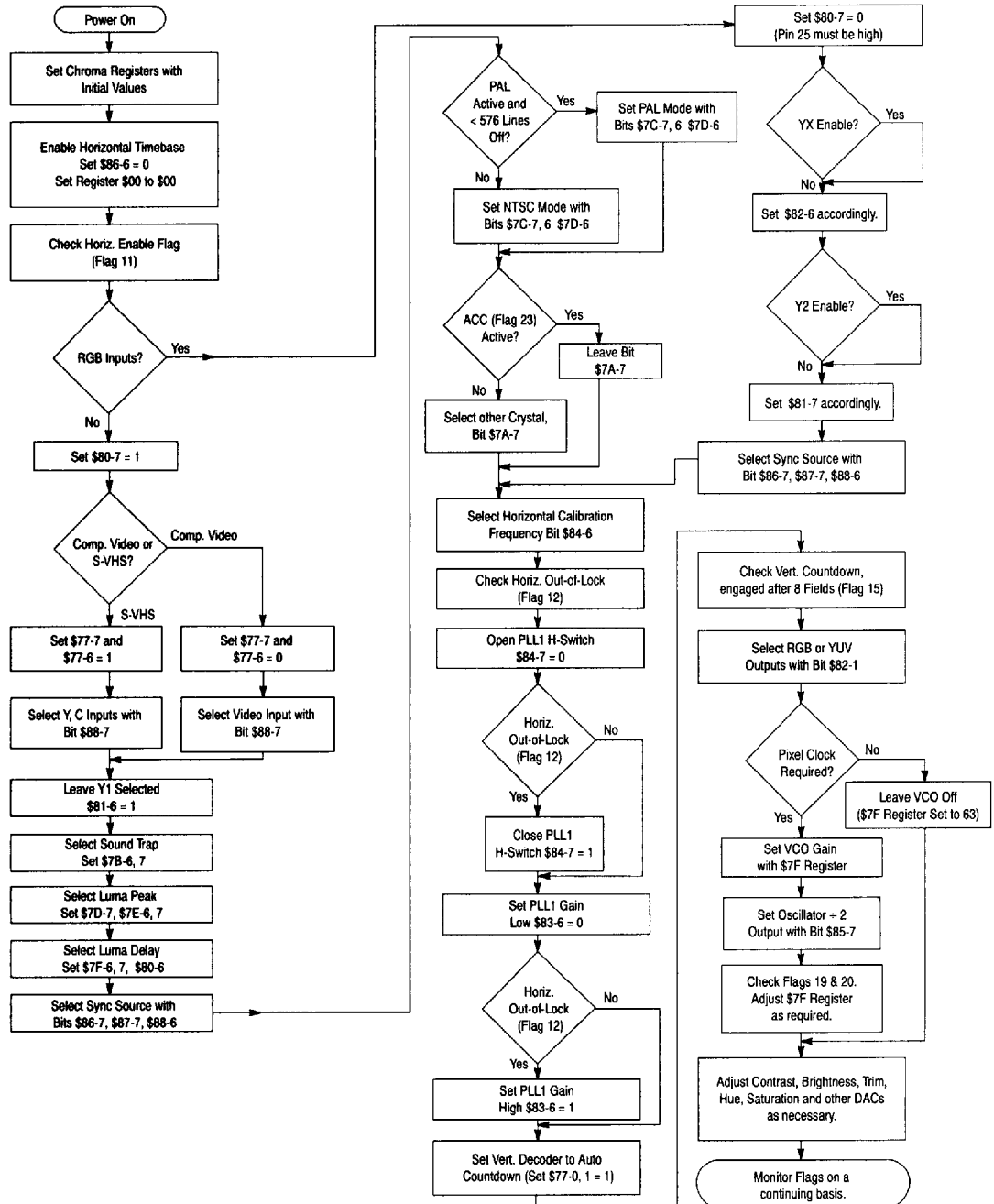

MC44011

APPENDIX C

I²C Description

Introduction

The I²C system, a patented and proprietary system developed by Philips Corporation, defines a two-wire communication system. The number of devices in a system is limited only by the system capacitance and data rate. Each device is assigned two unique addresses — one for writing to it, and one for reading from it. Any device may act as a master by initiating a data transfer with any other device (the slave).

Data transfer is in 8-bit bytes, and can be in either direction, but not in both directions in one data transfer operation.

Hardware Aspects

The system bus consists of two wires, Clock and Data. All devices must have open-collector (or open-drain) outputs. A single pull-up resistor is required on each line, as shown in Figure C1.

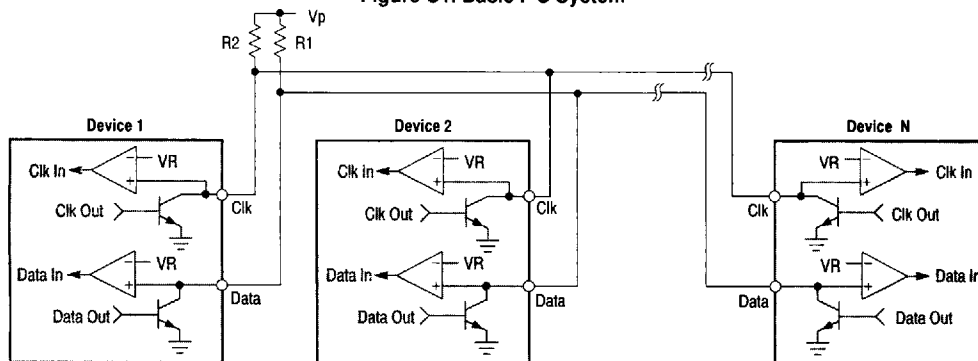
Figure C1. Basic I²C System

Devices such as the MC44011, which never act as a master, need not have the output drive transistor at the Clock pin. Nominal value for R1 and R2 is 10 k Ω , but can be different to account for system capacitance at high data rates. VR is a switching threshold for input signals.

The significant electrical characteristics are as follows:

- Maximum data rate (Clock frequency) is 100 kHz;
- V_{OL} max is 0.4 V when sinking 3.0 mA;
- V_{IL} max is $0.3 \times V_p$, but at least +1.5 V;
- V_{IH} min is +3.0 V for a +5.0 V system, or $0.7 \times V_p$ for other supply voltages.
- The maximum input current at Clock and Data at V_{OL} max (when they are inputs) is -10 μ A;
- The maximum input current at Clock and Data at $0.9 \times V_p$ (when they are inputs) is +10 μ A;
- The maximum pin capacitance is 10 pF;
- Maximum bus capacitance is 400 pF.

Data Transfer

Prior to initiating a data transfer, both lines must be high (all drive transistors off). A device which initiates a data transfer assumes the role of the master, and generates a START condition by taking the Data line low while Clock is still high. At this time, all other devices become listeners. The master will supply the clock for the entire sequence.

The master then sends the 8-bit address by operating both the clock and data lines. Data must be stable during the clock's high time, and can change during the clock's low time. The MSB is sent first. The address must end in a 0 if it is a Write operation (data transfer from master-to-slave), and it must end in a 1 if it is a Read operation.

At the 9th Clock Pulse, the master must release the Data line high, and the slave must provide an acknowledge bit by

pulling Data low during this clock time. If the master does not receive a proper acknowledge, it can terminate the operation.

After the first acknowledge, the role of the two devices depends on whether it is a Write or a Read operation, but the master always supplies the clock.

- In a Write operation the master is the transmitter, and the slave is the receiver.
- In a Read operation the slave is the transmitter, and the master is the receiver.

The transmitter then sends the next 8-bit byte. At the 18th Clock Pulse (and every 9th clock pulse thereafter), the transmitter releases the Data line, and the receiver acknowledges by pulling Data low. There is no limit to how many bytes may be sent after the address.

When all data is transferred, the Data line must be released by the transmitter so that the master can set the STOP condition. This is done by first pulling Data low (during clock low), then releasing Data high while clock is high. After this, the bus is free for any other device to initiate a new data transfer.

Definitions

Master - The device which initiates a data transfer (regardless of the data direction), generates the clock, and terminates the transfer.

Slave - The device addressed by the master.

Transmitter - The device which supplies data to the bus.

Receiver - The device which receives data from the bus.

Notice that the master is not necessarily the transmitter, and the slave is not necessarily the receiver.

Other

For additional information on the I²C bus specifications; modes of operation; arbitration; and synchronization, contact Philips Corporation.

MC44011

APPENDIX D

PLL Loop Theory

High Frequency Line-Locked Clock Generator

This section is not intended as a complete loop theory, its aim is merely to point out the idiosyncrasies of the loop, and provide the user with enough information for the selection of filter components. For a more in depth explanation, the references at the end of this section may be consulted.

Figure D1. PLL2 Basic Configuration

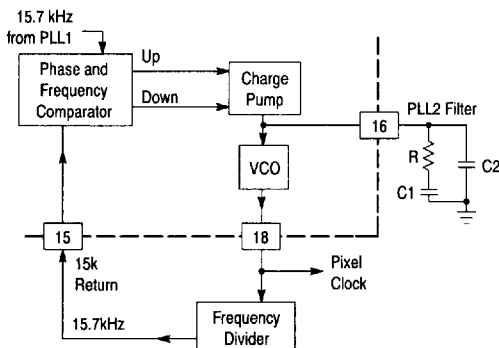

The following general remarks apply to the loop (PLL2):

- The loop frequency is ≈ 15.7 kHz.
- In spite of the samples nature of the loop, a continuous time approximation is possible if the loop bandwidth is sufficiently small.
- Ripple on V_C (filter pin) is a function of loop bandwidth.
- The loop is a type II, 3rd order. However, since C_2 is small, the pole it creates is far removed from the low frequency dominant poles, and the loop can be analyzed as a 2nd order loop.

The following remarks apply to the Phase and Frequency Comparator:

- Phase and frequency sensitive.
- Independent of duty cycle.
- It has 3 allowed states: up, down, and off (high impedance).
- The VCO is always pulled in the right direction during acquisition.
- The Comparator's gain is higher at or near lock.

The last two remarks imply that only the higher value need be taken into account, as acquisition will be slower but always in the correct direction, whereas the higher gain will come into action as soon as the error reaches 2π .

References:

- (1) *Charge-Pump Phase-Lock-Loops* by Floyd M. Gardner, IEEE Transactions on Communications, Vol. com-28, no. 11, Nov. 1980.
- (2) *Phaselock Techniques* by Floyd M. Gardner, J. Wiley & Sons, 1979.
- (3) *Phase-Locked-Loops* by Roland E. Best, McGraw Hill, 1984.
- (4) AN-535, *Phase-Locked-Loop Design Fundamentals*, Motorola.

The following values are selected and defined:

$C_2 = C_1/10$ or less, to satisfy the requirement that the effect of C_2 on the low frequency response of the loop be minimal, and similar to a 2nd order loop.

$\xi = 0.707$ (damping factor).

$\omega_i = 15750 \times 2\pi = 98960$ rad/sec (input frequency).

$\tau = RC$ as the loop filter

$K = K_o \times I_p \times R / (2\pi N)$ — the loop gain

$K' = K \times \tau = 4\xi^2$ (the normalized loop gain)

$K_o = 70 \times 10^6$ rad/V

Stability analysis with $C_2 = C_1/10$ and $K' = 2$ ($\xi = 0.707$) gives a minimum value of 7.5 for the ratio ω_i/K . To have some margin, a reasonable value can be 15 to 20 or higher.

Selecting $\omega_i/K = 20$ yields,
 $K = \omega_i/20 \approx 5000$.

Using the following items:

$K' = 2$,

$\tau = 2/K = 400 \mu s$,

$K = K_o \times I_p \times R / (2\pi N)$

$I_p = 20 \mu A$

$N = 2000$ (average value)

yields a value of 22 k Ω for R . Using a value of 400 μs for τ , C_1 calculates to 18 nF, and C_2 calculates to 1.8 nF.

With the above values, the loop's natural frequency (ω_n), and loop bandwidth (ω_{3dB}) can be calculated:

$\omega_n = \{(K_o/N) \times I_p / (2\pi C)\}^{0.5} = 3520$ rad/sec.

$f_n = 3520/2\pi = 560$ Hz.

$\omega_{3dB} \approx 2 \times \omega_n = 1120$ Hz (valid if $\xi = 0.707$).

The circuit designer should be cautioned at this point that the above calculated values are not necessarily optimum for every application. Besides the fact that several assumptions were made in the discussion, the equations cannot account for items such as the PC board layout, characteristics of the external divider, and noise from various sources. The above calculated values provide for a functional circuit, which should then be tweaked to obtain minimum jitter at the pixel clock output.

When initially adjusting the filter component values, it is advisable to maintain the same general time constant (400 μs in this example), and the same x10 relationship between C_1 and C_2 .

MC44011

GLOSSARY

Aspect Ratio – The ratio of the width of a TV screen to the height. In standard TVs, it is 4:3. In HDVT it will likely be 16:9.

Back Porch – The blanking time after the sync signal during which the color burst is inserted.

Black, Pedestal – The signal level which is either at black, or slightly more negative than black ("blacker-than-black"), and is used to turn off the screen dot during retrace. Also referred to as the *pedestal*.

Brightness – A measure of the DC levels of the luma component. Changing brightness will change the minimum and maximum luma levels together.

Burst – The 8 to 10 cycle sine wave which is inserted in the back porch. Its frequency is the color subcarrier (3.58 MHz or 4.43 MHz), and is used as a phase reference for the color decoder.

Burst Gate – A signal identifying the time during which the burst signal occurs.

C, Chrominance – The color component of the video signal. The color is determined by the phase of the chrominance component relative to the burst signal.

Clamping – A process which establishes a fixed DC voltage level, usually during the back porch time.

Color Difference Signals – B-Y, R-Y, also designated as U and V.

Color Decoder – A circuit which separates composite video into Red, Blue, and Green, luminance, and sync signals.

Color Encoder – A circuit which combines Red, Blue, and Green, luminance, and sync signals into composite video.

Comb Filter – A multi-bandpass filter which separates the luma and chrominance components from the video signal, without sacrificing bandwidth.

Component Video, YUV – A format whereby the video information is kept as separate luma, R-Y, and B-Y signals (YUV). U is the same as B-Y, and V is the same as R-Y.

Composite Sync – A sync signal which combines horizontal and vertical sync information. The waveform is made up of regularly spaced negative going pulses for the horizontal sync, and then half-line pulses and polarity reversal to indicate the vertical sync and retrace time.

Composite Video – The video signal which consists of sync, back porch, color burst, video information (luma and chroma), and front porch. This is the signal normally broadcast by TV stations.

Contrast – A measure of the difference between minimum and maximum luma amplitudes. Increasing contrast produces a "blacker" black and a "whiter" white.

dB – A power or voltage measurement unit, referred to another power or voltage. It is generally computed as:

$$10 \times \log (P1/P2) \text{ for power measurements, and}$$

$$20 \times \log (V1/V2) \text{ for voltage measurements.}$$

Field – One of the two or more equal parts into which a frame is divided in an interlaced system.

Frame – The information which makes up one complete picture. It consists of 525 lines in NTSC systems, and 625

lines in PAL systems. An interlaced system is typically composed of two fields.

Front Porch – The blanking time immediately before the sync signal.

Horizontal Sync – The negative going sync pulses at the beginning of each line. The pulses indicate to the circuit to begin sweeping the dot across the screen.

Hue – A measure of the correctness of the colors on a screen.

Interlaced System – A method of generating a picture on the screen whereby the even number lines are processed, and then the odd number lines are processed, thereby completing a full picture.

IRE – Abbreviation for *International Radio Engineers*, it is the amplitude unit used to define video levels. In standard NTSC signals, blank-to-white is 100 IRE units, and blank-to-sync tip is 40 IRE units. In a 1.0 Vp-p signal, one IRE unit is 7.14 mV.

Luma, Y – The brightness component of the video signal. Usually abbreviated "Y", it defines the shade of gray in a black-and-white TV set. In color systems, it is composed of 0.30 red, 0.59 green and 0.11 blue.

NTSC – *National Television System Committee*. This committee set the color encoding standards and format for television broadcast in the United States.

PAL – *Phase Alternating Line*. A color encoding system in which the burst is alternated 90° each line to help compensate for color errors which may occur during transmission. This system is popular mainly in Europe.

Pixel – The smallest picture element, or dot, on a screen. It is determined by the design of the CRT, as well as the system bandwidth.

R-Y, B-Y – Referred to as *color difference signals*. These are two of the three signals of component video. When combined with Y, the full color and luminance information is available.

Retrace – The rapid movement of the blanked dot from the screen's right edge to the left edge so it can start scanning a new line. It is also the rapid movement from the lower right corner to the upper left corner during vertical blanking.

RGB – The three main colors (*red, blue, green*) used in the acquiring, and subsequent display of a video signal.

S-VHS – A format whereby the video information is kept as separate luma and chroma signals (Y and C).

Sandcastle – A signal which indicates the horizontal blanking time. It encompasses the front porch, sync, and back porch. Two amplitudes distinguish the front porch + sync time from the back porch.

Saturation – A measure of the intensity of the color on a screen. Also related to its purity.

Sync Separator – A circuit which will detect, and output, the sync signal from a composite video waveform.

Vertical Sync – The synchronizing signal which indicates to the circuitry to drive the dot to the upper left corner of the screen, thereby starting a new field. This signal is derived from the composite sync.

This datasheet has been downloaded from:

www.DatasheetCatalog.com

Datasheets for electronic components.